



Weldmatic 350i + Weldmatic 500i



Weldmatic 350i
Multiprocess welder
Model No. CP139-2
Iss A



Weldmatic 500i
Multiprocess welder
Model No. CP140-2
Iss A

Operators Manual 02/18

Welding Industries of Australia

An ITW Company

Telephone: 1300 300 884
Facsimile: 1300 301 884
Email: Info@welding.com.au
www.welding.com.au

Weldwell New Zealand

A Division of ITW New Zealand

Telephone: 06 8341 600
Email: info@weldwell.co.nz
www.weldwell.co.nz



Contents

Section	General Information	Page
	Safe Practices	2
1	Introduction	5
2	Receiving	6
3	Specifications	7
4	Controls	8
5	Installation	10
6	Normal Welding Sequence	12
7	Basic Welding Information	12
8	General Maintenance	18
9	External Trouble Shooting	19
10	Service Information	20
	10.1 Circuit Diagram	21
11	Assembly and Parts Lists	22
12	Australia Warranty Information	24
12	New Zealand Warranty Information	25



Read First

The information contained in this manual is set out to enable you to properly maintain your new equipment and ensure that you obtain maximum operating efficiency.

Please ensure that this information is kept in a safe place for ready reference when required at any future time.

When ordering spare parts, please quote the model and serial number of the power source and part number of the item required. All relevant numbers are shown in lists contained in this manual. Failure to supply this information may result in unnecessary delays in supplying the correct parts.

Safety

Before this equipment is put into operation, please read the Safe Practices section of this manual. This will help to avoid possible injury due to misuse or improper welding applications.

Plastic Handles on Power Source

Please note that the handles fitted to the Weldmatic power source are intended for carrying the equipment by hand only.

DO NOT use these handles for suspending or mounting the power source in any other manner.

Safe Practices When Using Welding Equipment

These notes are provided in the interests of improving operator safety. They should be considered only as a basic guide to Safe Working Habits. A full list of Standards pertaining to industry is available from the Standards Association of Australia, also various State Electricity Authorities, Departments of Labour and Industry or Mines Department and other Local Health or Safety Inspection Authorities may have additional requirements. Australian Standard AS1674.2 provides a comprehensive guide to safe practices in welding.

Eye Protection

NEVER LOOK AT AN ARC WITHOUT PROTECTION. Wear a helmet with safety goggles or glasses with side shields underneath, with appropriate filter lenses protected by clear cover lens. This is a **MUST** for welding, cutting, and chipping to protect the eyes from radiant energy and flying metal. Replace the cover lens when broken, pitted, or spattered.

Recommended Shade Filter Lens

Amps	TIG	MMAW	MIG	Pulsed MIG
0-100	10	9	10	12-13
100-150	11	10	10	12-13
150-200	12	10-11	11-12	12-13
200-300	13	11	12-13	12-13
300-400	14	12	13	14
400-500	—	13	14	14
500 +	—	—	14	14

Burn Protection

The welding arc is intense and visibly bright. Its radiation can damage eyes, penetrate light-weight clothing, reflect from light-coloured surfaces, and burn the skin and eyes. Burns resulting from gas-shielded arcs resemble acute sunburn, but can be more severe and painful.

Wear protective clothing – leather or heat resistant gloves, hat, and safety-toed boots. Button shirt collar and pocket flaps, and wear cuffless trousers to avoid entry of sparks and slag.

Avoid oily or greasy clothing. A spark may ignite them. Hot metal such as electrode stubs and work pieces should never be handled without gloves.

Ear plugs should be worn when welding in overhead positions or in a confined space. A hard hat should be worn when others are working overhead.

Flammable hair preparations should not be used by persons intending to weld or cut.

Toxic Fumes

Adequate ventilation with air is essential. Severe discomfort, illness or death can result from fumes, vapours, heat, or oxygen depletion that welding or cutting may produce. **NEVER** ventilate with oxygen.

Lead, cadmium, zinc, mercury, and beryllium bearing and similar materials when welded or cut may produce harmful concentrations of toxic fumes. Adequate local exhaust ventilation must be used, or each person in the area as well as the operator must wear an air-supplied respirator. For beryllium, both must be used.

Metals coated with or containing materials that emit fumes should not be heated unless

coating is removed from the work surface, the area is well ventilated, or the operator wears an air-supplied respirator.

Work in a confined space only while it is being ventilated and, if necessary, while wearing air-supplied respirator.

Vapours from chlorinated solvents can be decomposed by the heat of the arc (or flame) to form phosgene, a highly toxic gas, and lung and eye irritating products. The ultra-violet (radiant) energy of the arc can also decompose trichlorethylene and perchlorethylene vapours to form phosgene. Do not weld or cut where solvent vapours can be drawn into the welding or cutting atmosphere or where the radiant energy can penetrate to atmospheres containing even minute amounts of trichlorethylene or perchlorethylene.

Fire and Explosion Prevention

Be aware that flying sparks or falling slag can pass through cracks, along pipes, through windows or doors, and through wall or floor openings, out of sight of the operator. Sparks and slag can travel up to 10 metres from the arc.

Keep equipment clean and operable, free of oil, grease, and (in electrical parts) of metallic particles that can cause short circuits.

If combustibles are present in the work area, do NOT weld or cut. Move the work if practicable, to an area free of combustibles. Avoid paint spray rooms, dip tanks, storage areas, ventilators. If the work can not be moved, move combustibles at least 10 metres away out of reach of sparks and heat; or protect against ignition with suitable and snug-fitting fire-resistant covers or shields.

Walls touching combustibles on opposite sides should not be welded on or cut. Walls, ceilings, and floor near work should be protected by heat-resistant covers or shields.

A person acting as Fire Watcher must be standing by with suitable fire extinguishing equipment during and for some time after welding or cutting if;

- Combustibles (including building construction) are within 10 metres.
- Combustibles are further than 10 metres but can be ignited by sparks.
- Openings (concealed or visible) in floors or walls within 10 metres may expose combustibles to sparks.
- Combustibles adjacent to walls, ceilings, roofs, or metal partitions can be ignited by radiant or conducted heat.

After work is done, check that area is free of sparks, glowing embers, and flames.

A tank or drum which has contained combustibles can produce flammable vapours when heated. Such a container must never be welded on or cut, unless it has first been cleaned as described in AS.1674-2. This includes a thorough steam or caustic cleaning (or a solvent or water washing, depending on the combustible's solubility), followed by purging and inerting with nitrogen or carbon dioxide, and using protective equipment as recommended in AS.1674-2. Water-filling just below working level may substitute for inerting.

Hollow castings or containers must be vented before welding or cutting. They can explode. Never weld or cut where the air may contain flammable dust, gas, or liquid vapours.

Shock Prevention

Exposed conductors or other bare metal in the welding circuit, or ungrounded electrically alive equipment can fatally shock a person whose body becomes a conductor. Ensure that the equipment is correctly connected and earthed. If unsure have the equipment installed by a qualified electrician. On mobile or portable equipment, regularly inspect condition of trailing power leads and connecting plugs. Repair or replace damaged leads.

Fully insulated electrode holders should be used. Do not use holders with protruding screws. Fully insulated lock-type connectors should be used to join welding cable lengths.

Terminals and other exposed parts of electrical units should have insulated knobs or covers secured before operation.

IMPORTANT NOTICE: Warranty may be voided if equipment is powered from an unsuitable engine driven generator.

Generators used to power this equipment must have the recommended minimum capacity and incorporate output voltage regulation.

Due to variation between generators by different manufacturers, it is impossible for WIA to validate operation from all generators. Therefore, we recommend that operation of equipment on the generator is received from the manufacturer before purchasing the generator.

1 Introduction

The Weldmatic is a multiprocess welding machine capable of Gas Metal Arc Welding (GMAW or MIG), Manual Metal Arc Welding (MMAW or Stick) and Gas Tungsten Arc Welding (GTAW or TIG).

GMAW (MIG Welding)

Gas Metal Arc Welding (GMAW) is an arc welding process where a consumable wire is fed by motor driven feed rolls to a welding gun, and where welding current is supplied from the welding power source. The welding arc is struck between the work piece and the end of the wire, which melts into the weld pool. The arc and the weld pool are both shielded by gas flow from the gun, or in the case of "self shielded" wires, by gases generated by the wire core.

The process is very versatile in that by selection of the correct wire composition, diameter and shielding gas, it can be used for applications ranging from sheet-metal to heavy plate, and metals ranging from carbon steel to aluminium alloys.

The Weldmatic has been designed to be used with consumable wires of different diameter. The smaller wire sizes are used when welding at lower currents, such as sheet-metal applications. Increasing the wire diameter permits higher welding currents to be selected.

A common application of GMAW is for welding Mild Steel. In this application, a Mild Steel solid consumable wire such as AUSTMIG ES6 is used with a shielding gas of Carbon Dioxide, or Argon mixed with Carbon Dioxide. Alternatively, Flux-cored consumable wires are available in both gas shielded, and 'gasless' self shielding types.

Stainless steel and Aluminium can be welded with GMAW using the correct consumable wire and shielding gas.

The Weldmatic wirefeeder has been designed to feed a range of hard, soft, and flux-cored wires for the GMAW process. A compact motor with integral gear box is coupled to a two roll drive assembly forming the basic component of the wirefeeder. The motor is controlled by an electronic speed control which provides speed regulation.

MMAW (Stick Welding)

Manual Metal Arc Welding (MMAW) is a process where an arc is struck between a flux-coated consumable electrode and the work piece. The arc and the weld pool are both shielded by gases generated by the flux coating of the electrode.

The Weldmatic has been designed to be used with 2.0mm, 2.5mm, 3.2mm and 4.0mm diameter electrodes. The smaller electrodes are used when welding at lower currents, such as sheet metal applications. Increasing the electrode diameter permits higher welding currents to be selected.

WIA supplies a wide range of mild steel and special purpose electrodes which cater for home workshop, rural, and industrial requirements. Some popular AUSTARC electrodes are listed below. The correctly selected AUSTARC electrode will influence the quality of the weld, and the stability of the arc.

Austarc 12P, Classification E4313-A

A popular general purpose electrode used with ease in all positions, vertical up or down. The smooth forceful arc makes it an ideal electrode for all general mild steel applications.

Austarc 13S, Classification E4313-A

A smooth running electrode with a soft arc, particularly suited to light sheetmetal and smooth mitre fillet welds.

Austarc 16TC, Classification E4916-A

A low hydrogen electrode with good arc stability and out-of-position welding characteristics. This electrode is ideal for medium carbon steels, or steels of unknown analysis.

Austarc 11, Classification E4311-A

A high cellulose electrode for all positional welding, AC or DC. Particularly suited for vertical and incline pipe welding where complete root penetration is required.

Unicord 312, Classification ES312-16

A high tensile (50tsi), chromium nickel electrode specially formulated for joining all alloy steels and irons, and for tool and die maintenance.

GTAW (TIG Welding)

Gas Tungsten Arc Welding (GTAW) is a welding process where the arc is struck between a non-consumable tungsten electrode and the work piece. A ceramic nozzle surrounds the tungsten electrode and directs a flow of inert gas, usually Argon, over the electrode and the weld zone. If filler metal is required, it is hand fed into the welding arc. The DC current output of the Weldmatic is suitable for welding most ferrous and non-ferrous metals, but is not suitable for welding Aluminium for which an AC machine is required.

2 Receiving

Check the equipment received against the shipping invoice to make sure the shipment is complete and undamaged. If any damage has occurred in transit, please immediately notify your supplier.

The Weldmatic 350i package contains;

- CP139-2 Weldmatic 350i power source.
- Argon gas regulator.
- Gas hose
- Welding torch – 350 AMP fitted with Bernard 0.9 centre fire tip
- Work lead and spring clamp - 10m x 35mm² cable with large twist lock connector.
- W66-0 wire feeder with 4 roll drive.
- Feed roller V0.9/1.2mm with Vgroove quantity 2 fitted
- Feed roller V0.9/1.2mm with teeth (knurled) quantity 2 spare
- Composite lead 35mm² 10M
- AM358 trolley with drawers
- Owners Manual CP139-40

The Weldmatic 500i package contains;

- CP140-2 Weldmatic 500i power source.
- Argon gas regulator
- Welding torch - 400amp fitted with 0.9mm Bernard centre fire tip
- Work lead and clamp - 10m x 50mm² cable terminated with G clamp
- W65-0 wire feeder with heavy duty 4 roll drive
- Feed roller V0.9/1.2mm with Vgroove quantity 2 fitted
- Feed roller V0.9/1.2mm with teeth (knurled) quantity 2 spare
- COMPOSITE LEAD 50mm² 10M
- AM358 Trolley with drawers
- Owners Manual CP139-40

Optionally available

- TIG Torch Complete TIG002, 4m cable with twist-lock connection and fitted with 2.4mm collet. Manual Gas valve on hand piece

3 Specifications

	350i	500i
Manufactured to Standards	AS60974.1 IEC60974.10	AS60974.1 IEC60974.10
Rated Input Voltage	380 – 415V 3 Phase	380 – 415V 3 Phase
Power Frequency	50/60 Hz	50/60 Hz
Generator Three Phase Capacity	15KVA	25KVA
Rated Maximum Supply Current I_{max}	25A	37A
Maximum Effective Supply Current I_{eff}	19.4A	28.7A
Output No Load Voltage	65V	65V
VRD Safe	4.1V	4.1V
MIG GMAW		
	350Amp @ 31.5V 60% Duty	500Amp @ 39V 60% Duty
	271Amp @ 27.6V 100% Duty	387Amp @ 33.4V 100% Duty
Stick MMA		
	350Amp @ 34V 60% Duty	490Amp @ 39.6V 60% Duty
	271Amp @ 30.8V 100% Duty	380Amp @ 35.2V 100% Duty
TIG		
	350Amp @ 24V 60% Duty	500Amp @ 30V 60% Duty
	271Amp @ 20.8V 100% Duty	387Amp @ 25.5V 100% Duty
Spool Size	ES6 – 5kg & 15kg	ES6 – 5kg & 15kg
Supply Plug	32A	32A
Supply Cable	2.5mm ² 3 Core + E Heavy Duty PVC	4.0mm ² 3 Core + E Heavy Duty PVC
Mains Circuit Breaker Rating	25A	32A
Wire Speed Range	0-15 Metre/sec	0-20 Metre/sec
Wire Size	0.8, 0.9, 1.2 mm Solid Wire 0.8 - 1.2 mm Cored Wire	0.8, 0.9, 1.6 mm Solid Wire 0.8 - 1.6 mm Cored Wire
Cooling Type	Fan on Demand	Fan On Demand
Efficiency	≥ 85%	≥ 85%
Power Factor	0.92	0.92
Insulation	H 140°C Rise	H 140°C Rise
Protection	IP21S	IP21S
Weight	93kg	96kg
Shipping Weight	104kg	107kg
Dimension L x W x H	705 x 307 x 500mm	705 x 307 x 500mm
Shipping Dimension L x W x H	1070 x 550 x 1080mm	1070 x 550 x 1080mm

4 Controls

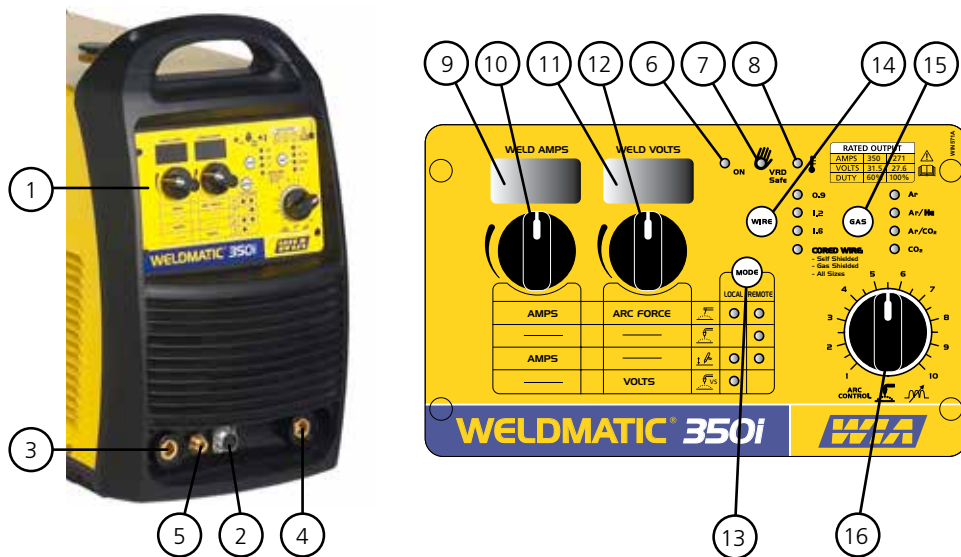

Fig 1 Weldmatic 350i + 500i Controls

1 Control Panel

2 Remote Connector

There are two remote connectors, the larger one is for the wire feeder connection and the other is for a remote control connection, such as a TIG torch.

3 Positive Welding Output Terminal

4 Negative Welding Output Terminal

5 Gas Connection

6 Power On Indicator

7 VRD Safe Light

VRD safe light is on when the open circuit output voltage is reduced to a safe level.

8 Over Temperature Warning

If an over temperature condition is reached the machine will prevent weld output and wait until machine has cooled down, before welding output can commence.

9 Digital Display Amps

If Weld Mode is stick MMA Mode or TIG mode the display will indicate the selected welding Amps when adjusted with knob, item (10).

During welding in any mode, the display will show actual welding Amps.

10 Weld Current Adjustment

Weld Current Adjustment Knob for Stick MMA or TIG Mode.

11 Digital Display Volts

MIG Mode (GMAW): the display will indicate Actual weld volts.

Stick Mode (MMA): the display will indicate the amount of Arc Force 0-10 set by Knob (12).

Voltage Sensing (VS): the display will indicate the weld volts setting set by Knob (12).

12 Voltage Adjustment Knob

When in Stick MMA Mode the knob will adjust Arc force 0-10.

When the welding machine detects a sudden drop in the weld arc voltage, the machine will compensate momentarily by increasing the weld current and weld voltage.

A higher arc force might be useful for difficult electrodes such as Cellulose.

If Weld Mode is Voltage Sensing VS the knob will adjust the weld volts setting

13 Mode Selection Button

Pressing the button will cycle through each of the six welding modes as indicated by the six lights. The Six Modes are:

13.1 Stick electrode welding MMA, with LOCAL control: The two knobs will adjust Weld amps and Arc force.

13.2 Stick electrode welding MMA, with REMOTE control: The two knobs will adjust maximum Weld amps and Arc force. The remote control will provide arc start switch and knob control of weld amps, up to the maximum AMPS setting.

13.3 GMAW MIG using remote wire feeder: The weld voltage is controlled from the wire feeder and the set value is displayed on (11). The output voltage is only active when signaled from the wire feeder.

13.4 TIG GTAW welding, LOCAL control:

Lift arc start, using TIG welding torch with separate gas supply.

Knob (10) will adjust the weld current which is displayed on (9).

13.5 TIG GTAW welding REMOTE control:

Lift arc start, using TIG welding torch with separate gas supply.

Knob (10) will adjust the Maximum weld current which is displayed on (9).

The remote control knob will control weld amps 0-100% of the maximum setting.

The maximum current is set by adjusting the remote knob to maximum, then adjust the front panel knob (10) to the desired maximum setting.

13.6 MIG Mode Voltage Sensing VS: The Knob (12) will adjust the weld volts setting, which is displayed on (11).

The output terminals are at full OCV. This mode requires a special wire feeder that is capable of operating from output live terminals.

Note: Mode selection switch must be pressed for 3 seconds, to lock into VS mode.

14 Wire select Button and Indicator

Use this button to select the wire size being used. Sizes 0.9, 1.2, 1.6mm can be used.

When wire setting is set to Gasless then

there is no need to select wire size.

15 Gas Select button and indicator

Use this button to select which type of gas is being used, or if Gasless wire is being used.

Ar: Argon is typically used for Aluminium welding and Silicon Bronze welding.

Ar/He: Argon Helium is used for stainless steel.

Ar/CO2: Is used for Argon CO2 mixed gas. There are a variety of gas mixes available. Argon CO2 is typically used on thicker steel, Argon CO2 O2 mix is used for thin steel.

CO2: Is a cheaper gas option for steel when weld spatter and finish is not a concern.

16 Arc Control

When in MIG GMAW mode the harshness of the arc can be adjusted. For example aluminium welding would require a different setting to steel welding.

5 Installation

Connection to Electrical Mains Power Supply

Note: All electrical work shall only be undertaken by a qualified electrician.

350i

The Weldmatic 350i is factory fitted with a 3 metre, 3 core+ earth 2.5mm² Heavy Duty PVC mains power supply cable.

The power cable is fitted with a 32 amp 3 phase plug.

Maximum rated output

To achieve the rated output of 350A 60% the machine requires maximum primary current I_{max} 25A and Effective primary current I_{eff} 20 Amps.

The machine needs to be fitted with a plug capacity 20A or greater, and a supply capacity 25A or greater.

The minimum recommended supply circuit breaker rating for a Weldmatic 350i is 25 Amps.

500i

The Weldmatic 500i is factory fitted with a 3 metre, 3 core+ earth 4.0mm² Heavy Duty PVC mains power supply cable.

The power cable is fitted with a 32 amp 3 phase plug.

Maximum rated output

To achieve the rated output of 500A 60% the machine requires maximum primary current I_{max} 37A and Effective primary current I_{eff} 30 Amps.

The machine needs to be fitted with a plug capacity 32A or greater, and a supply capacity 28.7A or greater.

The minimum recommended supply circuit breaker rating for a Weldmatic 500i is 32 Amps.

Successful operation

Successful operation will depend on a number of factors:

- Variation in circuit breaker thresholds.
- Ambient temperature.
- Number of previous circuit breaker operations.
- Actual weld conditions, resulting in higher weld currents.
- Repeated starts can result in repeated in-rush currents raising circuit breaker threshold.

Repeated circuit breaker operation at weld start can sometimes be overcome by using a "D" curve circuit breaker.

To reduce nuisance tripping, a higher rated circuit breaker can be selected, but the supply circuit wiring capacity must be increased to suit.

Supply Cable

If it becomes necessary to replace the mains flexible supply cable, use only cable with correct current rating.

The replacement cable must be fitted and retained in the same manner as the original.

Output Voltage Polarity

The design of the Weldmatic allows selection of the output voltage polarity.

Positive Wire

MIG welding (GMAW), with solid consumable wires and gas shielding, is carried out with the work piece Negative and the welding wire Positive.

To setup for this condition, connect the 'WORK' lead plug into the (-) output terminal on the power source, and the wirefeeder weld cable into the (+) output terminal.

Negative Wire

Some 'self-shielded' flux cored gasless consumable wires are operated with the work piece Positive and the consumable wire Negative. Refer to the manufacturers data for the particular consumable wire to be used.

To setup for this condition, connect the 'WORK' lead plug into the (+) output terminal on the power source, and the wirefeeder weld cable into the (-) output terminal.

Fitting the Gas Cylinder

Place the gas cylinder on the tray at the rear of the optional welder trolley (if using). Retain the cylinder with the chain provided.

Fit the gas regulator to the cylinder. DO NOT apply grease or oil to these joints.

Fit the end of the gas inlet hose from the back of the power source to the connector supplied with the gas regulator, and secure with the clamp also supplied.

6 Normal Welding Sequence

Weld Start

Closing the welding gun switch initiates this sequence of events:

- The gas valve is energised and gas flow commences;
- Welding voltage is applied between the work piece and the consumable wire.
- The wire drive motor is energised.
- The wire touches the work piece, and the arc is established.

Weld End

Releasing the gun switch initiates this sequence of events:

- The wire drive motor is de-energised, and is dynamically braked to a stop;
- The welding current stops.
- The gas valve is de-energised and the flow of shielding gas ceases.

The quality of the consumable wire greatly affects how reliably a gas metal arc welder will operate. For best results when welding mild steel, we recommend quality WIA AUSTMIG ES6. Dirty, rusty or kinked wire will not feed smoothly through the gun cable and will cause erratic welding. Deposits from the wire will clog the gun cable liner requiring it to be replaced prematurely.

7 Basic Welding Information

MIG Welding (GMAW)

Choice of Shielding Gas

The choice of shielding gas is largely determined by the consumable wire to be used. Many proprietary shielding gas mixtures are available.

Some recommended shielding gases are:

- Mild Steel Argon + 18% Oxygen ;
Argon + 2% Oxygen +
5% Carbon dioxide;
- Aluminium Argon;
- Stainless Steel Argon + 1 to 2%
Oxygen.
Argon + Helium

Consult your gas supplier if more specific information is required.

Shielding Gas Flow Rate

In GMAW, one function of the shielding gas is to protect the molten weld pool from the effects of oxygen in the atmosphere. Without this protection the weld deposit becomes 'honeycombed' in appearance, an effect which is described as weld porosity.

In draft-free conditions the gas flow rate required to give adequate protection is typically 10-12 litres/min. In situations where drafts cannot be avoided, it may be necessary to increase this rate up to 20 litres/min, and/or to provide screening of the work area.

Weld porosity can also be caused by air entering the gas stream through a damaged hose, loose gas connection, or from restriction in the nozzle, such as from excess build-up of spatter.

When welding aluminium, particular care must be taken with all aspects of shielding gas delivery and work piece preparation in order to avoid weld porosity.

Establishing a Weld Setting

Once the consumable wire type, wire size and shielding gas have been chosen, the two variables that are adjusted in order to obtain a the desired weld setting are;

- Wirefeed speed,
- Welding arc voltage.

The wirefeed speed determines the welding current; increasing the speed increases the current, and decreasing it decreases current.

The selected wirefeed speed must be matched with sufficient arc voltage; a speed increase requires an increase of arc voltage.

If the voltage is too low the wire will stub and stutter, and there will not be a steady arc. If the voltage is too high the arc will be long with metal transfer occurring as a series of large droplets.

The weld setting should be chosen to suit the application and the thickness of the metal to be welded. It is important to check that the deposited weld provides sufficient strength to suit the application.

A “good” weld will have the characteristics illustrated in Figure 2. The weld has penetrated into the parent metal, fusing the root of the joint where the two plates meet, and the weld blends smoothly into the side walls.

A “bad” weld is shown in Figure 3. The weld has not penetrated the joint root, and there is poor side wall fusion. This lack of fusion would normally be corrected by increasing the arc voltage, or by increasing both wirefeed speed and arc voltage to achieve a higher current weld setting.

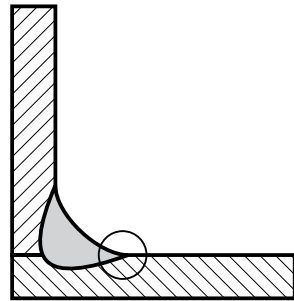

Fig 2 “Good” Weld

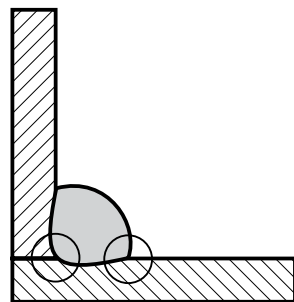

Fig 3 “Bad” Weld

Gun Position

For "down hand" fillet welding with gas shielded solid wires, the gun is normally positioned as shown in Figure 4a below, with the nozzle end pointing in the direction of travel.

For "down hand" fillet welding with gasless flux cored wires, the gun is normally positioned as shown in Figure 4b, with the nozzle end pointing away from the direction of travel, referred to as 'dragging' the weld. Gasless flux cored wires should be operated with approximately 10-15mm of wire 'stick-out' from the welding contact tip as shown in Figure 4c.

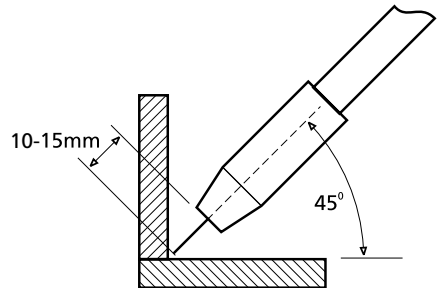

Fig 4c Wire Stickout for Gasless Welding

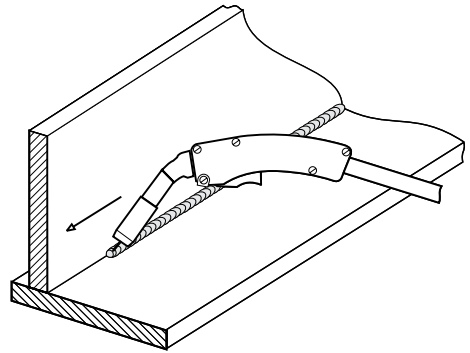

Fig 4a Gas Shielded Solid Wires

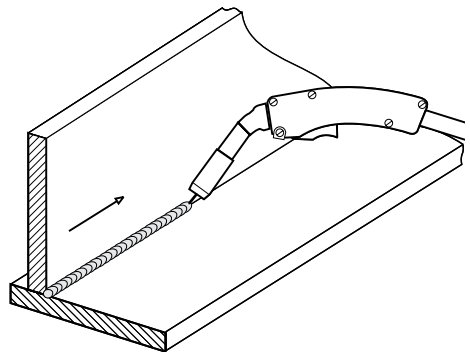

Fig 4b Gasless Flux Cored Wires

Stick Welding (MMAW)

Connection for Stick Welding

It is important to select the electrode polarity in accordance with the manufacturers recommendations for that electrode. Most common electrodes, including cellulose types, are operated with the electrode at positive polarity.

Stick Welding Operation

Be certain that you are wearing suitable protective clothing, gloves etc and that you are working in a non-hazardous area. If necessary, refer again to **Section 1 - Safe Practices** in this manual.

Connect the work clamp to the work piece. Place the desired electrode in the electrode holder (electrode holder optional extra).

Turn on the power switch located on the rear panel. Wait approximately 5 seconds as the unit goes through its initiation sequence.

Press the Weld Mode button until the Stick Mode light is on.

Select an appropriate welding current for the electrode diameter by setting the knob on the machine front panel. WIA Austarc electrodes will give the best results.

To strike the arc, drag the end of the electrode along the work piece as if striking a match. As the arc initiates, lift the electrode slightly away, aiming to establish an arc length of approximately 3 mm.

As the electrode end is consumed, feed the electrode into the arc in order to maintain arc length. As a general rule, the arc should be held as short as possible while still giving stable burn off and good weld appearance. An arc which is too long cause an unwieldy flow of metal with a rough weld appearance and reduced penetration.

An arc too short leads to a narrow weld deposit and “stuttery” arc characteristics, and the electrode is liable to freeze onto the work piece.

As the solidified weld deposit forms, move the end of the electrode slowly along the weld path, aiming to maintain a pool of molten weld metal behind the arc. Decreasing this rate of travel will result in a wider weld deposit, and similarly increasing it will narrow the weld deposit.

Always fill the crater which tends to form at the end of a weld deposit, by pausing momentarily before withdrawing the electrode to break the arc. Unfilled craters are a point of weakness, and can lead to weld cracking.

Current Range for General Purpose Electrodes

Diameter (mm)	Current (Amps)
2.0	40 -60
2.5	60 - 85
3.2	90 - 130
4.0	130 - 180

Stick Remote Mode

When in stick remote Mode, the output can be turned on and off with a remote switch connected to the remote plug.

TIG Welding (GTAW)

Connection for TIG Welding

For TIG welding, the torch is connected to the negative terminal. Welding grade Argon is the shielding gas most commonly used for DC GTAW welding. The gas is connected directly to the torch.

Before first use of the welding torch, allow gas to purge the torch and hoses for 1 minutes at approximately 10 litres/min. For welding purposes, the gas flow rate should be set in the range 2-5 litres/min.

Tungsten electrodes for DC GTAW should be 1-2% Thoriated or Witstar. This type will provide the best arc initiation, arc stability and tip shape retention characteristics. Thoriated electrodes can be recognised by a red coded end. The tungsten electrode is ground to a point, with the grinding marks pointing towards the tip. For welding currents less than 20 amps, the included angle of the point should be 30°, for currents greater than 20 amps, the recommended angle is 60°. When set in the torch, the tungsten should protrude 6 mm from the ceramic gas nozzle.

TIG Welding Operation

Connect the Work Clamp to the work piece.

Turn on the power switch located on the rear panel. Wait approximately 5 seconds as the unit goes through its initiation sequence.

Press the Weld Mode button until the TIG Mode light is on. The Weldmatic keeps the last mode used in memory, so this step is only necessary when using a different mode to that used last.

Select an appropriate welding current for the job by setting the knob on the machine front panel.

Use of a copper striking plate can be used to avoid electrode contamination. The electrode can also be contaminated by contact with the filler rod. A contaminated electrode produces an unstable arc. If this occurs regrind the electrode tip.

TIG Local / Remote Mode

When in Local Mode the output is turned on and the LIFT-ARC voltage is present at the electrode.

When in Remote Mode the output can be adjusted by a remote potentiometer connected to the remote plug.

LIFT TIG Operation

LIFT TIG arc start can be achieved with the following procedure.

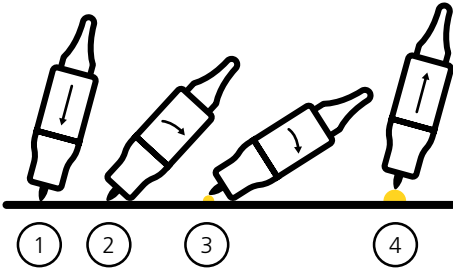

Fig 5 Lift TIG Operation Procedure

- 1 Turn on the shielding gas.
- 2 Touch the electrode lightly against the work piece.
- 2 Press the torch trigger switch (if in remote mode). The shielding gas will start to flow and a small current will pass through the electrode.
- 4 While still holding the electrode against the work piece, roll the hand piece over until the cup rests on the work piece.
Use the cup as a pivot point to roll the hand piece over allowing the electrode to lift of the work piece.
The arc will ignite.
- 5 Immediately lift the cup of the work piece, the current will rise to the welding level.

Duty Cycle

The term duty cycle indicates the percentage welding time available at the rated output current, for each 10 min period over 4 hours.

The Weldmatic 350i is rated at 350 Amps, and the 500i at 500 Amps, 60% duty cycle. If the machine is operated at a reduced welding current, a higher duty cycle is available. The diagram below illustrates the appropriate duty cycle rating for the range of welding currents available, and so allows the maximum welding time per 10 minute period to be determined.

The power source is protected by in built over temperature protection devices. These will operate if the machine is operated in excess of its current and duty cycle rating. If this occurs, the temperature warning indicator will be on, the fan will continue to run, but the machine will not deliver welding current until the unit has cooled sufficiently.

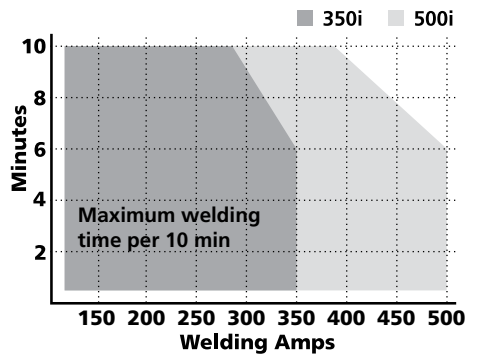

Fig 6 Duty Cycle Rating

8 General Maintenance

Before removing the equipment cover, ENSURE that the equipment is disconnected from the mains power supply. When the equipment is energised LETHAL VOLTAGES are present on the electrical components enclosed.

Dust

Care should be taken to prevent excessive build-up of dust and dirt within the welding power source. It is recommended that at regular intervals, according to the prevailing conditions, the equipment covers be removed and any accumulated dust be removed by the use of dry, low pressure compressed air, or a vacuum cleaner.

Wirefeed

In order to obtain the most satisfactory welding results from the GMAW process, the wirefeed must be smooth and constant. Most causes of erratic wirefeed can be cured by basic maintenance. Check that the:

- 1 Feed rolls are the correct size and type for the wire in use. Check also that the drive groove is aligned with the wire, and that the groove is not worn;
- 2 Gun cable liner is clear of dust and swarf build-up. When replacement becomes necessary, fit only the correct liner. The build-up of dust can be minimised by regular purging of the liner with dry compressed air. This may be conveniently done each time the wire spool is replaced;
- 3 Welding tip is free of obstructions such as spatter build-up. Ream out the tip bore with a suitable size oxy-tip cleaner. Replace the welding tip as it becomes worn;
- 4 Feed roll pressure is not excessive. The pressure should be just sufficient to feed the wire evenly. Excessive pressure will deform the electrode wire and make feeding more difficult;
- 5 Consumable wire spool holder rotates smoothly and that the braking action is not excessive. The spool should only have sufficient braking to prevent over run when the motor stops. This also may be conveniently checked each time the wire is replenished;
- 7 Welding wire is straight and free of buckles or 'waviness'. To check, remove 2 or 3 metres of wire from the spool. Clamp one end in a vice or similar, then holding the other end pull the wire out straight. Look down the length of the wire, any buckles will be obvious. Buckled wire is extremely difficult to feed reliably and should be replaced;
- 8 Welding wire is free of surface rust. Replace if rust is evident.

9 External Trouble Shooting

If you are in Australia and the following checks do not identify the fault condition, the equipment should be returned to a WIA Service agent. Phone 1300 300 884 for details of your nearest service agent.

If you are in New Zealand and the following checks do not identify the fault condition, the equipment should be returned to the original place of purchase with proof of purchase, or contact Weldwell on 06 8341 600.

Power source has no output and no wirefeed when gun switch is closed :

'ON' indicator light is not illuminated

- 1 Check equipment is connected to a functional mains power outlet. Test outlet using a known working appliance.
- 2 Check fuse on rear panel

'ON' indicator light is illuminated

- 1 The gun switch circuit may be incomplete.
 - Check the gun switch for continuity with an ohm meter when the switch is pressed. Replace if faulty
 - Check the 2 pin receptacles in Euro adaptor are making contact with the mating pins from the gun Euro end.

- 2 Power source may have overheated.
 - The Weldmatic welding power source incorporates an in-built over-temperature thermostat which will trip if the welding load exceeds the operating duty cycle. The 'OVERLOAD' light will be illuminated. The thermostat will reset automatically - do not switch the equipment off as the cooling fan will assist the resetting of the thermostat
 - If problem persists after the cool down period, call your WIA service agent.

Power source has low weld output

- 1 Check all electrical connections in the welding current circuit, including weld cable, work clamp and gun/cable assembly.

Circuit breaker trips during welding

- 1 Check the rating of the mains supply circuit breaker. The Weldmatic should be supplied from a suitable circuit breaker (refer to section 5).

Unsatisfactory Welding Performance and Results

Erratic arc characteristics caused by poor wirefeed

Erratic wirefeed is the MOST LIKELY cause of failure in all Gas Metal Arc Welding. It should therefore be the first point checked when problems occur.

- 1 Check the torch contact tip is not worn. A worn tip can cause arcing to the wire inside the tip and cause the wire to stick and hesitate
- 2 Check if the consumable wire is slipping in the drive rolls. Replace the feed roll if it is the incorrect size or is worn

10 Service Information

- 3 Check that gun cable liner is not too short and is fitted correctly. Refer wirefeeder manual for fitting instructions.

Constant poor arc characteristics

Check that the:

- 1 Correct polarity has been selected for work and weld cables
- 2 Shielding gas is correct for the consumable wire in use
- 3 Welding circuit is making good electrical connection. Ensure that the work clamp is securely tightened onto the work piece so that good electrical contact is achieved
- 4 All connections in the external welding circuit are clean and tight. Problems may show as hot spots
- 5 Work piece surface is not contaminated. Water, oil, grease, galvanising, paint, or oxide layers can severely disturb the welding arc and result in a poor weld.

Porosity in weld caused by lack of shielding gas

- 1 Check that the correct gas flow rate has been set
- 2 Check for leaks in the gas hose. Replace if leaking
- 3 Check for leaks in gun/cable assembly, eg. fractured gas hose, broken or missing 'O' rings. Replace as required
- 4 Check the gun nozzle is free from spatter and is firmly attached to the welding gun to ensure that no air is being drawn into the shielded area.

The following information is intended for use by qualified service personnel. When the unit is energised LETHAL VOLTAGES are present on the electrical and electronic components. It is not intended that persons without suitable training and knowledge attempt to perform service tasks on the components of this welder.

Before removing the equipment cover, ENSURE that the equipment is disconnected from the mains power supply. When the equipment is energised LETHAL VOLTAGES are present on the electrical components enclosed.

10.1 Circuit Diagrams – Power Source

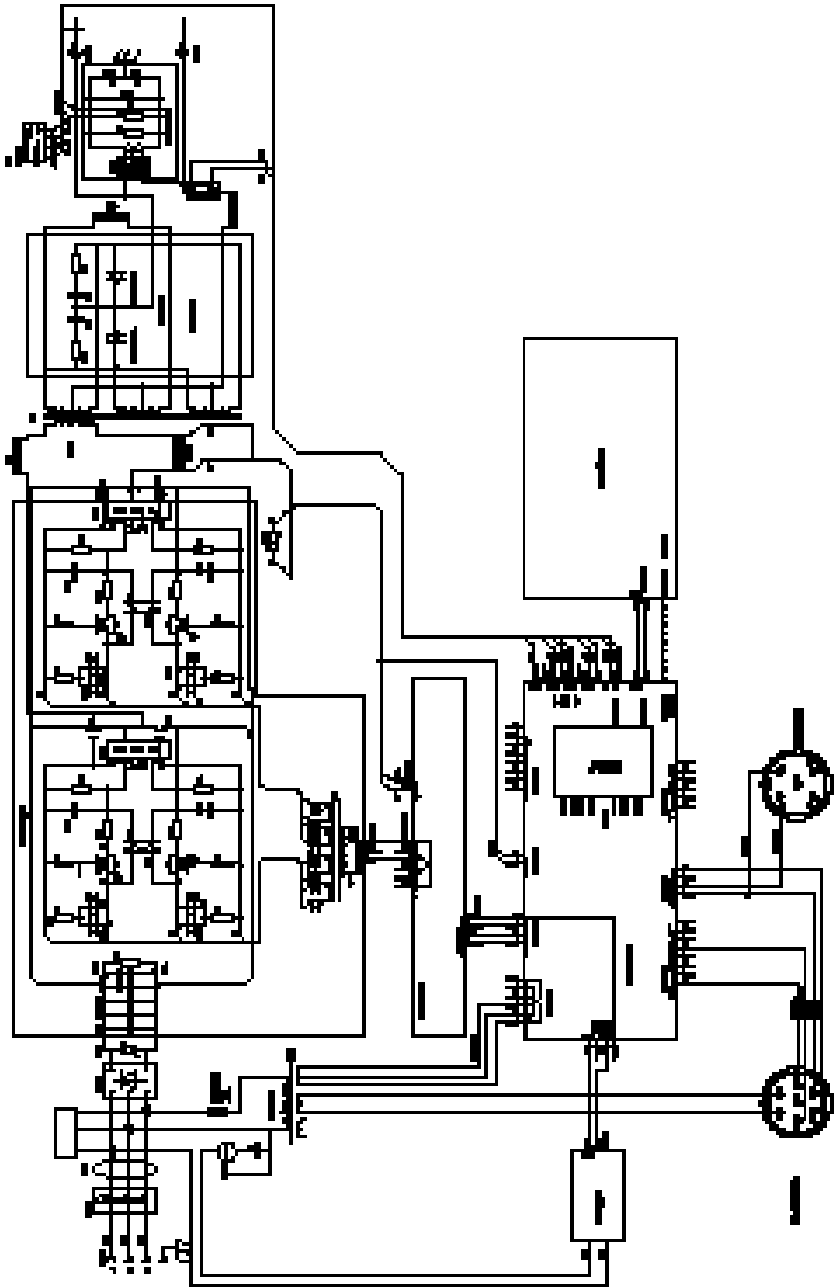

Fig 7 Weldmatic 350i + 500i Circuit Diagram

11.1 Assembly and Parts List - Weldmatic 350i/500i

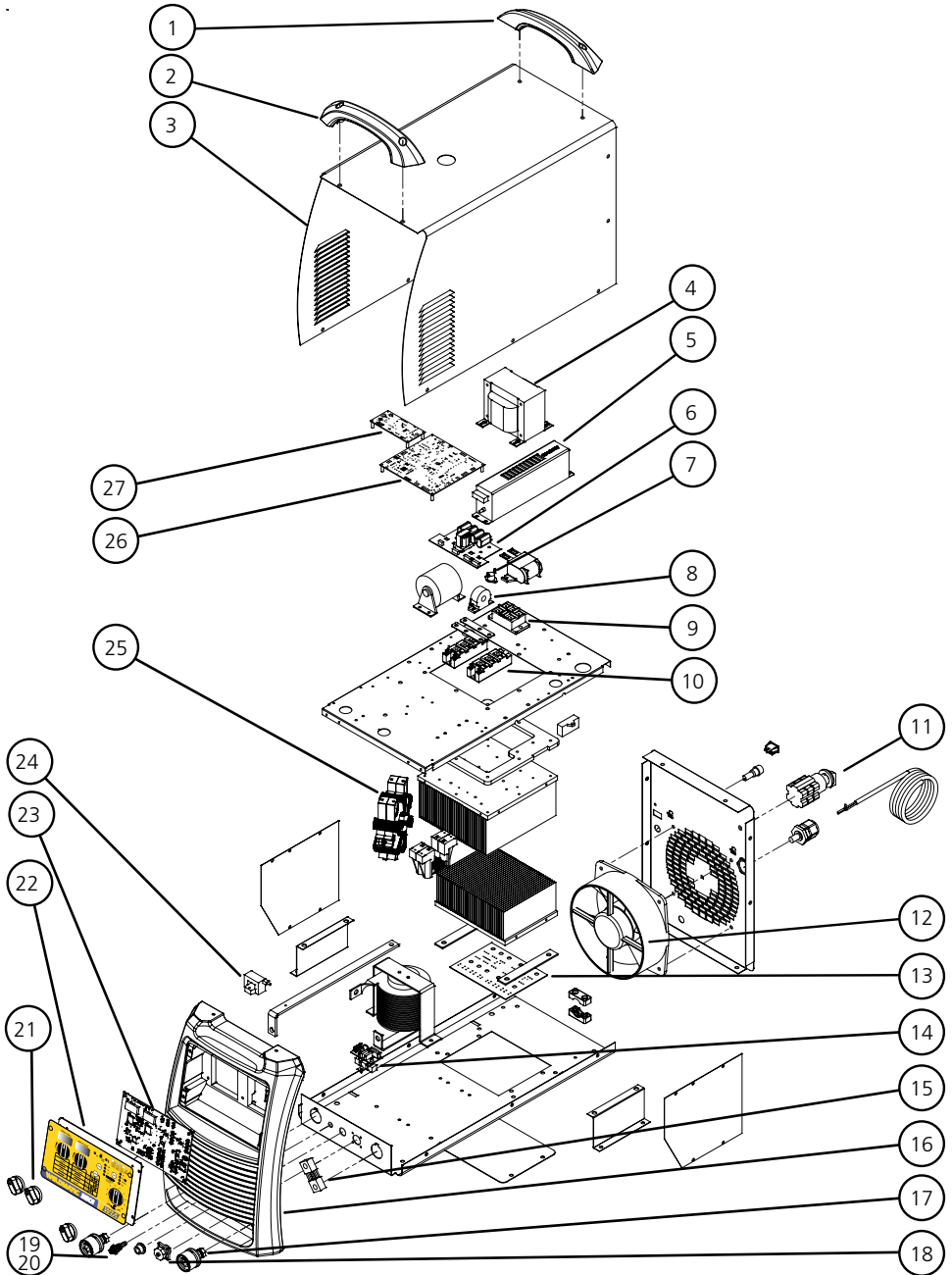

Fig 8 Weldmatic 350i/500i Assembly

Item #	Part #	Description	Qty
1/2	M0071	Handle	2
3	PAN164	Enclosure	1
4	L0027	Control Transformer	1
5	E0084	Input Filter 500i	1
5	E0083	Input Filter 350i	1
6	PWA033	PCB Assembly 350i 500i	1
7	E0085	Thermostat	1
8	L0028	Toroid Input 350i 500i	1
9	D0042	Rectifier 3 PH 350i 500i	1
10	D0041	IGBT CP140 500i	2
11	E0081	Switch On/Off	1
12	FAN009	Fan 350i	1
12	FAN016	Fan 500i	1
13	PWA035	PCB Connection	1
14	PWA034	Output Snubber	1
15	E0086	Current Shunt	1
16	M0076	Front Panel Plastic	1
17	CX58	Weld Terminal Panel Mount Dinse Socket	2
18	E0082	Socket 7 PIN	1
19	TC265	5/8" UNF Nipple	1
20	TC266	5/8" UNF Nut	1
21	M0047	Knob	3
22	WIN571	Front Sticker 350i	1
22	WIN573	Front Sticker 500i	1
23	PWA031	PCB Assy Front Panel 350i 500i	1
24	L0029	Toroid Output 350i 500i	1
25	L0031	Weld Transformer 500i	1
25	L0030	Weld Transformer 350i	1
26	PWA036	PCB Assy PTAP500-CRTL 350i 500i	1
27	PWA037	PCB Assy PM500-WAY 350i 500i	1
	WHL002	Wheel Castor	2
	WHL003	Wheel Fixed	2
	REG003	Argon Regulator	1
	CP139-40	Operating Manual	1
	62513	Gas Hose	

12 Australian Warranty Information



WIA Weldmatic MIG & Multi-Process Equipment

3 Year Warranty Statement

Welding Industries of Australia (WIA) warrants to the original retail purchaser that the Weldmatic welding machine purchased (Product) will be free from defects in materials and workmanship for a period of 3 years from the date of purchase of the Product by the customer. If a defect in material or workmanship becomes evident during that period, Welding Industries of Australia will, at its option, either:

- Repair the Product (or pay for the costs of repair of the Product); or
- Replace the Product.

In the event of such a defect, the customer should return the Product to the original place of purchase, with proof of purchase, or contact Welding Industries of Australia on 1300 300 884 to locate an authorised service agent.

Any handling and transportation costs (and other expenses) incurred in claiming under this warranty are not covered by this warranty and will not be borne by Welding Industries of Australia. Welding Industries of Australia will return the replacement product, if original found to be faulty, freight free to the customer.

This warranty covers the Weldmatic power source and wirefeeder only, and does not extend to the regulator, gun assembly or accessories included in the original purchase package.

The obligation of Welding Industries of Australia under this warranty is limited to the circumstances set out above and is subject to:

- The customer being able to provide proof of purchase of the Product and the purchase price paid for the Product;
- The relevant defect in materials or workmanship;
- The Product not having been altered, tampered with or otherwise dealt with by any person in a manner other than as intended in respect of the relevant Product; and
- The Product not having been used or applied in a manner that is contrary to customary usage or application for the relevant Product or contrary to any stated instructions or specification of Welding Industries of Australia.

Our goods come with guarantees that cannot be excluded under the Australian Consumer Law. You are entitled to a replacement or refund for a major failure and for compensation for any other reasonably foreseeable loss or damage. You are also entitled to have the goods repaired or replaced if the goods fail to be of acceptable quality and the failure does not amount to a major failure. The benefits given by this warranty are in addition to other rights and remedies which may be available to the customer under any law in relation to goods and services to which this warranty relates.

Warranty provided by:
Welding Industries of Australia
(ABN 63 004 235 063)

A Division of ITW Australia Pty Ltd
5 Allan Street, Melrose Park,
South Australia, 5039

Ph: 1300 300 884
Email: info@welding.com.au
Web: www.welding.com.au

13 New Zealand Warranty Information



New Zealand Warranty

WIA Weldmatic MIG & Multi-Process Equipment purchased in New Zealand have identical 3 year warranty conditions as Australia, with the below conditions:

In the event of defects listed in the Australian warranty conditions, the customer should return the Product to the original place of purchase, with proof of purchase, or contact Weldwell on 06 8341600.

The warranty shall not apply to parts that fail due to normal wear.

For customers located in New Zealand, you can contact:

Weldwell New Zealand
Division of ITW New Zealand

64 Thames Street
Napier 4110
New Zealand

Ph: 06 8341 600

Email: info@weldwell.co.nz

Miller Digital Elite Series™

AUTO-DARKENING HELMETS

Inferno P/N - 257217 Joker P/N - 257218

Lucky's Speed Shop P/N - 257214 Black P/N - 257213

FOUR MODES – WELD, CUT, GRIND & X-MODE



- Lens and helmet comply with Australian Standards AS/NZS 1338.1 (Auto-Darkening) and AS/NZS 1337.1 B (High Impact)
- Lightweight at only 510g.
- Improved digital controls.
- Battery powered with solar assist.

- Lightweight headgear.
- Four independent arc sensors.
- Suits MIG, Stick, Flux-Cored and Pulse.
- TIG rating 5 Amps.
- 3 year warranty (Auto-Darkening lens only).

For more information call 1300 300 884 or visit welding.com.au

