



WIA

WELDMATIC (200)

MIG & Multi-Process Welder

OPERATORS MANUAL | CP150-1



From serial numbers C1502A*

WELD WITH THE BEST.

WELDING.COM.AU

WELDING INDUSTRIES AUSTRALIA

A Division of ITW Australia Pty Ltd
ABN: 63 004 235 063

1300 300 884

Email: info@welding.com.au
welding.com.au

WELDWELL NEW ZEALAND

A Division of ITW New Zealand
NZBN: 9 429 039 833 129
GST NO: 080177186

0800 9353 9355

Email: info@weldwell.co.nz
weldwell.co.nz

CONTENTS

Section	General Information	Page
	Safe Practices	4
1	Introduction	7
2	Receiving	9
3	Specifications	10
4	Controls	12
5	Installation	14
6	Normal Welding Sequence	17
7	Basic Welding Information	17
8	General Maintenance	26
9	External Trouble Shooting	27
10	Trouble Shooting Chart	28
11	Service Information	31
	11.1 Circuit Diagram	32
12	Assembly & Parts Lists	
	12.1 Power Source	33
	12.2 Wirefeeder	35
	12.3 Gun & Cable	36
13	Australian Warranty Information	38
14	New Zealand Warranty Information	40

READ FIRST

The information contained in this manual is set out to enable you to properly maintain your new equipment and ensure that you obtain maximum operating efficiency.

Please ensure that this information is kept in a safe place for ready reference when required at any future time.

When ordering spare parts, please quote the model and serial number of the power source and part number of the item required. All relevant numbers are shown in lists contained in this manual. Failure to supply this information may result in unnecessary delays in supplying the correct parts.

SAFETY

Before this equipment is put into operation, please read the Safe Practices section of this manual. This will help to avoid possible injury due to misuse or improper welding applications.

PLASTIC HANDLES ON POWER SOURCE

Please note that the handles fitted to the Weldmatic power source are intended for carrying the equipment by hand only.

DO NOT use these handles for suspending or mounting the power source in any other manner.

SAFE PRACTICES WHEN USING WELDING EQUIPMENT

These notes are provided in the interests of improving operator safety. They should be considered only as a basic guide to Safe Working Habits. A full list of Standards pertaining to industry is available from the Standards Association of Australia, also various State Electricity Authorities, Departments of Labour and Industry or Mines Department and other Local Health or Safety Inspection Authorities may have additional requirements. Australian Standard AS1674.2 provides a comprehensive guide to safe practices in welding.

Eye Protection

NEVER LOOK AT AN ARC WITHOUT PROTECTION. Wear a helmet with safety goggles or glasses with side shields underneath, with appropriate filter lenses protected by clear cover lens. This is a **MUST** for welding, cutting, and chipping to protect the eyes from radiant energy and flying metal. Replace the cover lens when broken, pitted, or spattered.

Recommended Shade Filter Lens

Amps	TIG	MMAW	MIG	Pulsed MIG
0-100	10	9	10	12-13
100-150	11	10	10	12-13
150-200	12	10-11	11-12	12-13
200-300	13	11	12-13	12-13
300-400	14	12	13	14
400-500	–	13	14	14
500 +	–	–	14	14

Burn Protection

The welding arc is intense and visibly bright. Its radiation can damage eyes, penetrate light-weight clothing, reflect from light-coloured surfaces, and burn the skin and eyes. Burns resulting from gas-shielded arcs resemble acute sunburn, but can be more severe and painful.

Wear protective clothing – leather or heat resistant gloves, hat, and safety-toed boots. Button shirt collar and pocket flaps, and wear cuff less trousers to avoid entry of sparks and slag.

Avoid oily or greasy clothing. A spark may ignite them. Hot metal such as electrode stubs and work pieces should never be handled without gloves.

Ear plugs should be worn when welding in overhead positions or in a confined space. A hard hat should be worn when others are working overhead.

Flammable hair preparations should not be used by persons intending to weld or cut.

Toxic Fumes

Adequate ventilation with air is essential. Severe discomfort, illness or death can result from fumes, vapours, heat, or oxygen depletion that welding or cutting may produce. **NEVER** ventilate with oxygen.

Lead, cadmium, zinc, mercury, and beryllium bearing and similar materials when welded or cut may produce harmful concentrations of toxic fumes. Adequate local exhaust ventilation must be used, or each person in the area as well as the operator must wear an air-supplied respirator. For beryllium, both must be used.

Metals coated with or containing materials that emit fumes should not be heated unless coating is removed from the work surface, the area is well ventilated, or the operator wears an air-supplied respirator.

Work in a confined space only while it is being ventilated and, if necessary, while wearing air-supplied respirator.

Vapours from chlorinated solvents can be decomposed by the heat of the arc (or flame) to form phosgene, a highly toxic gas, and lung and eye irritating products. The ultra-violet (radiant) energy of the arc can also decompose trichlorethylene and perchloroethylene vapours to form phosgene. Do not weld or cut where solvent vapours can be drawn into the welding or cutting atmosphere or where the radiant energy can penetrate to atmospheres containing even minute amounts of trichlorethylene or perchloroethylene.

Fire and Explosion Prevention

Be aware that flying sparks or falling slag can pass through cracks, along pipes, through windows or doors, and through wall or floor openings, out of sight of the operator. Sparks and slag can travel up to 10 metres from the arc.

Keep equipment clean and operable, free of oil, grease, and (in electrical parts) of metallic particles that can cause short circuits.

If combustibles are present in the work area, do NOT weld or cut. Move the work if practicable, to an area free of combustibles. Avoid paint spray rooms, dip tanks, storage areas, ventilators. If the work can not be moved, move combustibles at least 10 metres away out of reach of sparks and heat; or protect against ignition with suitable and snug-fitting fire-resistant covers or shields.

Walls touching combustibles on opposite sides should not be welded on or cut. Walls, ceilings, and floor near work should be protected by heat-resistant covers or shields.

A person acting as Fire Watcher must be standing by with suitable fire extinguishing equipment during and for some time after welding or cutting if;

- Combustibles (including building construction) are within 10 metres.
- Combustibles are further than 10 metres but can be ignited by sparks.
- Openings (concealed or visible) in floors or walls within 10 metres may expose combustibles to sparks.
- Combustibles adjacent to walls, ceilings, roofs, or metal partitions can be ignited by radiant or conducted heat.

After work is done, check that area is free of sparks, glowing embers, and flames.

A tank or drum which has contained combustibles can produce flammable vapours when heated. Such a container must never be welded on or cut, unless it has first been cleaned as described in AS.1674-2. This includes a thorough steam or caustic cleaning (or a solvent or water washing, depending on the combustible's solubility), followed by purging and inerting with nitrogen or carbon dioxide, and using protective equipment as recommended in AS.1674-2. Water-filling just below working level may substitute for inerting.

Hollow castings or containers must be vented before welding or cutting. They can explode. Never weld or cut where the air may contain flammable dust, gas, or liquid vapours.

Shock Prevention

Exposed conductors or other bare metal in the welding circuit, or ungrounded electrically alive equipment can fatally shock a person whose body becomes a conductor. Ensure that the equipment is correctly connected and earthed. If unsure have the equipment installed by a qualified electrician. On mobile or portable equipment, regularly inspect condition of trailing power leads and connecting plugs. Repair or replace damaged leads.

Fully insulated electrode holders should be used. Do not use holders with protruding screws. Fully insulated lock-type connectors should be used to join welding cable lengths.

Terminals and other exposed parts of electrical units should have insulated knobs or covers secured before operation.

1 INTRODUCTION

The Weldmatic is a multiprocess welding machine capable of Gas Metal Arc Welding (GMAW or MIG), Manual Metal Arc Welding (MMAW or Stick) and Gas Tungsten Arc Welding (GTAW or TIG).

GMAW (MIG Welding)

Gas Metal Arc Welding (GMAW) is an arc welding process where a consumable wire is fed by motor driven feed rolls to a welding gun, and where welding current is supplied from the welding power source. The welding arc is struck between the work piece and the end of the wire, which melts into the weld pool. The arc and the weld pool are both shielded by gas flow from the gun, or in the case of “self shielded” wires, by gases generated by the wire core.

The process is very versatile in that by selection of the correct wire composition, diameter and shielding gas, it can be used for applications ranging from sheet-metal to heavy plate, and metals ranging from carbon steel to aluminium alloys.

The Weldmatic has been designed to be used with consumable wires of different diameter. The smaller wire sizes are used when welding at lower currents, such as sheet-metal applications. Increasing the wire diameter permits higher welding currents to be selected.

A common application of GMAW is for welding Mild Steel. In this application, a Mild Steel solid consumable wire such as AUSTMIG ES6 is used with a shielding gas of Carbon Dioxide, or Argon mixed with Carbon Dioxide. Alternatively, Flux-cored consumable wires are available in both gas shielded, and ‘gasless’ self shielding types.

Stainless steel and Aluminium can be welded with GMAW using the correct

consumable wire and shielding gas.

The Weldmatic wirefeeder has been designed to feed a range of hard, soft, and flux-cored wires for the GMAW process. A compact motor with integral gear box is coupled to a two roll drive assembly forming the basic component of the wirefeeder. The motor is controlled by an electronic speed control which provides speed regulation.

MMAW (Stick Welding)

Manual Metal Arc Welding (MMAW) is a process where an arc is struck between a flux-coated consumable electrode and the work piece. The arc and the weld pool are both shielded by gases generated by the flux coating of the electrode.

The Weldmatic 200 has been designed to be used with 2.0mm, 2.5mm, 3.2mm and 4.0mm diameter electrodes. The smaller electrodes are used when welding at lower currents, such as sheet metal applications. Increasing the electrode diameter permits higher welding currents to be selected.

WIA supplies a wide range of mild steel and special purpose electrodes which cater for home workshop, rural, and industrial requirements. Some popular AUSTARC electrodes are listed below. The correctly selected AUSTARC electrode will influence the quality of the weld, and the stability of the arc.

Austarc 12P, Classification E4313-A

A popular general purpose electrode used with ease in all positions, vertical up or down. The smooth forceful arc makes it an ideal electrode for all general mild steel applications.

Austarc 13S, Classification E4313-A

A smooth running electrode with a soft arc, particularly suited to light sheetmetal and smooth mitre fillet welds.

Staincord 316L-016, Classification E316L-16

For quality all position stainless steel welding. Extra smooth running, high arc stability, easy re-strike, excellent slag removal and bead appearance.

Staincord 309Mo-16, Classification E309LMo-16

For high quality all position stainless steel welding. This extra low carbon alloy is specifically indicated for AISI 309Mo type alloys, but is also ideal for joining mild/low alloy steel to a range of 300 and 400 series stainless steels. Features extra smooth running, high arc stability, easy re-strike, excellent slag removal and bead appearance.

Austarc 16TC, Classification E4916-A

A low hydrogen electrode with good arc stability and out-of-position welding characteristics. This electrode is ideal for medium carbon steels, or steels of unknown analysis.

Unicord 312, Classification ES312-16

A high tensile (50tsi), chromium nickel electrode specially formulated for joining all alloy steels and irons, and for tool and die maintenance.

GTAW (TIG Welding)

Gas Tungsten Arc Welding (GTAW) is a welding process where the arc is struck between a non-consumable tungsten electrode and the work piece. A ceramic nozzle surrounds the tungsten electrode and directs a flow of inert gas, usually Argon, over the electrode and the weld zone. If filler metal is required, it is hand fed into the welding arc. The DC current output of the Weldmatic 200 is suitable for welding most ferrous and non-ferrous metals, but is not suitable for welding Aluminium for which an AC machine is required.

Equipment options		Part #
TIG Torch	(135A complete with valve, 4m cable with twist-lock connection and fitted with 2.4mm collet and thoriated tungsten)	TIG001
Trolley Kit		
Gas Bottle + Drawer		AM357

2 RECEIVING

Check the equipment received against the shipping invoice to make sure the shipment is complete and undamaged. If any damage has occurred in transit, please immediately notify your supplier.

The Weldmatic 200 package contains:

- Weldmatic 200 Power Source
- Euro MIG Gun and Cable Assembly
- Twist-lock Electrode Holder
- Work Clamp 3m
- Gas Hose
- Drive Roll 0.6/0.8 V Groove
- Drive Roll 0.9/1.2 Knurled
- Sample wire ES6 0.8mm
- Sample wire Austfil T-11 0.9mm Gasless
- Tips 0.6, 0.8, 0.9, 1.2mm
- Argon Flow Gauge Regulator REG003
- (This) Operating Manual CP150-40.

IMPORTANT NOTICE: Warranty may be voided if equipment is powered from an unsuitable engine driven generator.

Generators used to power this equipment must have the recommended minimum capacity and incorporate output voltage regulation.

Due to variation between generators by different manufacturers, it is impossible for WIA to validate operation from all generators. Therefore, correct operation of welding equipment on the generator should be confirmed by the manufacturer, before purchasing the generator.

3 SPECIFICATIONS

		WELDMATIC 200
Manufactured to Standards		AS60974.1 IEC60974.10
Rated Input Voltage		220 – 240V
Power Frequency		50/60 Hz
Generator Single Phase Capacity		12 kVA Peak
Rated Maximum Supply Current I_{max}		36A
Maximum Effective Supply Current I_{eff}		14A
Output No Load Voltage		71V
VRD Safe		13.5V
Rated Output @40°C 10 Min Cycle Time		
MIG Gmaw	10% Duty	
	15% Duty	200Amps @ 24V
	20% Duty	
	100% Duty	77Amps @ 17.9V
Stick MMA	10% Duty	
	15% Duty	170Amps @ 26.8V
	20% Duty	
	100% Duty	66Amps @ 22.6V
TIG	10% Duty	
	15% Duty	200Amps @ 18V
	20% Duty	
	100% Duty	77Amps @ 13.1V

3 SPECIFICATIONS (CONT)

WELDMATIC 200	
Spool Size	ES6 – 1kg & 5kg
Supply Plug	15Amp
Supply Cable	2.5mm ² 3 Core Heavy Duty PVC
Mains Circuit Breaker Rating	25A
Wire Speed Range	2-14.5 Metre/min
Wire Size (Solid)	0.6mm-0.9mm
Wire Size (Cored)	0.8-1.2mm
Cooling Type	Air cooling
Efficiency	≥ 85%
Power Factor	0.62
Insulation	H 140°C Rise
Protection	IP21S
Weight	15kg
Shipping Weight	25kg
Dimension L x W x H	525 x 260 x 410mm
Shipping Dimension L x W x H	705 x 320 x 495mm

4 CONTROLS

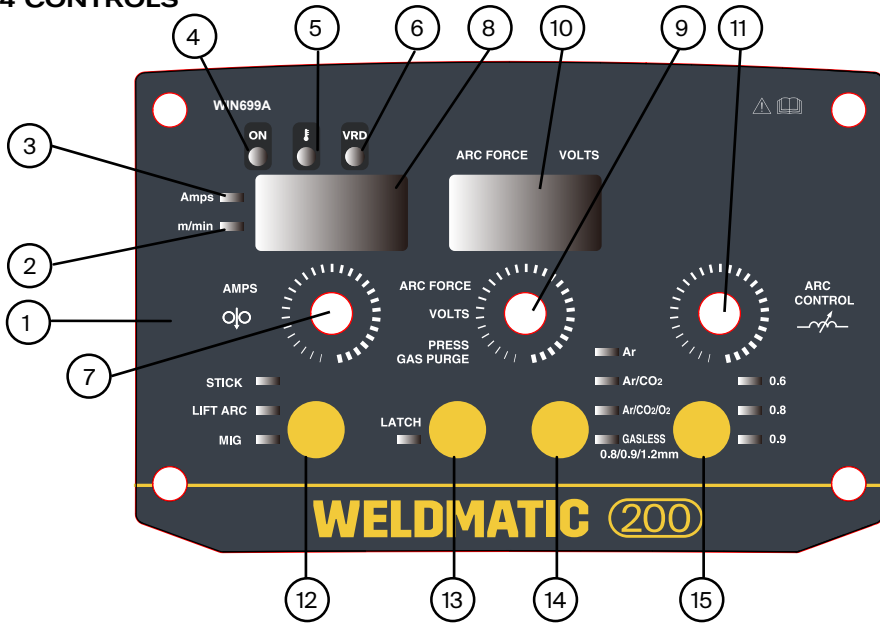

Fig 1 Weldmatic 200 Controls

1 Control Panel

2 m/min Indicator

When this light is on the Digital Display (8) is indicating the selected wire speed in metres per minute (MIG Mode).

3 Amps Indicator

When this light is on the Digital Display (8) is indicating the selected Amps (Stick or TIG Mode).

4 Power On Indicator

5 Over Temperature Indicator

This light is on if the machine overheats or mains voltage is too high or low – the machine will prevent weld output until the machine has cooled down or mains voltage returns to normal. Welding output can then recommence.

6 VRD Safe Indicator

This light is on when the machine is in Stick Mode (MMAW) and the output voltage is reduced to a safe level, in accordance with AS1672.2 2007 Category C.

7 Weld Current & Wire Speed Adjustment Control

Stick Mode (MMAW) and TIG Mode:

This control sets the Weld Current level.

MIG Mode (GMAW): This control sets Wire Speed.

8 Digital Display – Amps or m/min

During welding actual welding Amps will be displayed and then held for 30 seconds after the end of the weld.

Stick Mode (MMAW) or TIG Mode

(GTAW): The Amps Indicator (3) light will be on and the selected welding Amps will be displayed when adjusted with Weld Current & Wire Speed Adjustment Control (7).

MIG Mode (GMAW): The m/min Indicator light (6) will be on and the wire speed in metres per minute (m/min) will be displayed when adjusted with Weld Current & Wire Speed Adjustment Control (7).

9 Voltage Adjustment Control/Purge Knob

Stick Mode: Adjusts Arc Force (0-10). When the welding machine detects a sudden drop in the weld arc voltage, the machine will compensate momentarily by increasing the weld current and weld voltage. A higher arc force might be useful for difficult electrodes such as Cellulose.

MIG Mode: Adjusts weld volts.

Purge: Press to open the gas solenoid valve without energising the welding power source.

10 Digital Display – Volts

During welding actual welding Volts will be displayed and then held for 30 seconds after the end of the weld.

Stick Mode: The amount of Arc Force (0-10) will be displayed.

MIG Mode: Weld Volts will be displayed when adjusted with Voltage Adjustment Control (9).

11 Arc Control

When in MIG (GMAW) mode the harshness of the arc can be adjusted.

For example aluminium welding would require a different setting to steel welding.

12 Mode Selection Button

Press this button to step between modes. A mode is selected when the light is on.

There are three weld modes available:

- Stick Electrode Welding (MMAW)
- TIG Welding (GTAW): Lift arc start, using TIG welding torch with separate gas supply.
- MIG Welding (GMAW) Using MIG welding torch and gas-shielded or gasless welding wire.

13 Latch Select Button and Indicator

Press this button to select and deselect Latch Mode. When Latch Mode is selected, the operator needs to close the gun switch momentarily to commence welding, and again momentarily to end welding. This can help to reduce operator fatigue during long welding runs.

14 Gas Select Button and Indicator

Press to select which type of gas is being used, or if gasless wire is being used. See page 15 for information on selecting the shielding gas.

15 Wire Select Button and Indicator

Press to select the wire size being used. Sizes 0.6, 0.8mm or 0.9mm.

When Gas setting is set to Gasless then there is no need to select wire size. Sizes 0.8mm, 0.9mm or 1.2mm can be used.

5 INSTALLATION

Do Not Touch Live Electrical Parts

Touching live electrical parts can cause fatal shocks or severe burns. The electrode and work circuit is electrically live whenever the output is on. The input power circuit and machine internal circuits are also live when power is on. In semi-automatic wire welding, the wire, wire reel, drive roll housing, and all metal parts touching the welding wire are electrically live. Incorrectly installed or improperly grounded equipment is a hazard. Do not touch live electrical parts. **ELECTRIC SHOCK can kill.** Wear dry, hole-free insulating gloves and body protection. Insulate yourself from work and ground using dry insulating mats or covers big enough to prevent any physical contact with the work or ground.

Connection to Electrical Mains Power Supply

The Weldmatic 200 is factory fitted with a 3 metre, 3 core 2.5mm² Heavy Duty PVC mains power supply cable with moulded 3 pin, 15 Amp, Single Phase plug.

A 15 Amp plug and socket is recognisable by a wide Earth pin. Power Supply authorities require that equipment fitted with a 15 Amp plug shall **ONLY** be connected to a 240 Volt, 15 Amp power point. **DO NOT** modify the plug.

The minimum capacity of the mains wiring and power outlet supplying a welder is selected according to the effective primary current of the equipment. The effective primary current left for the Weldmatic 200 is 14 Amps.

The minimum recommended mains circuit breaker rating for a Weldmatic 200 is 20 Amps.

Supply Cable

If it becomes necessary to replace the mains flexible supply cable, use only cable with correct current rating.

The replacement cable must be fitted and retained in the same manner as the original.

Successful Operation

Successful operation will depend on a number of factors:

- Variation in circuit breaker thresholds.
- Ambient temperature
- Number of previous circuit breaker operations
- Actual weld conditions, resulting in higher weld currents
- Repeated starts can result in repeated surge currents raising circuit breaker threshold
- Low supply voltage can result in higher current

Repeated Circuit breaker operation at weld start can sometimes be overcome by using a "D" curve circuit breaker.

To reduce nuisance tripping, a higher rated circuit breaker can be selected, but the supply circuit wiring capacity must be increased to suit.

MIG Welding (GMAW)

Output Voltage Polarity

The design of the Weldmatic allows selection of the output voltage polarity.

Positive Wire

MIG welding (GMAW), with solid consumable wires and gas shielding, is carried out with the work piece Negative and the welding wire Positive.

To setup for this condition, connect the 'WORK' lead plug into the (-) output terminal on the power source, and the Polarity Selection Cable from the power source into the (+) output terminal, as in Figure 2.

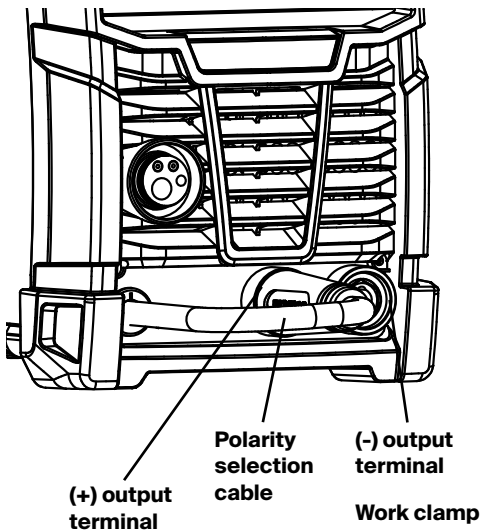

Fig 2 Positive Wire

Negative Wire

Some 'self-shielded' flux cored gasless consumable wires are operated with the work piece Positive and the consumable wire Negative. Refer to the manufacturers data for the particular consumable wire to be used.

To setup for this condition, connect the 'WORK' lead plug into the (+) output terminal on the power source, and the Polarity Selection Cable from the power source into the (-) output terminal, as in Figure 3.

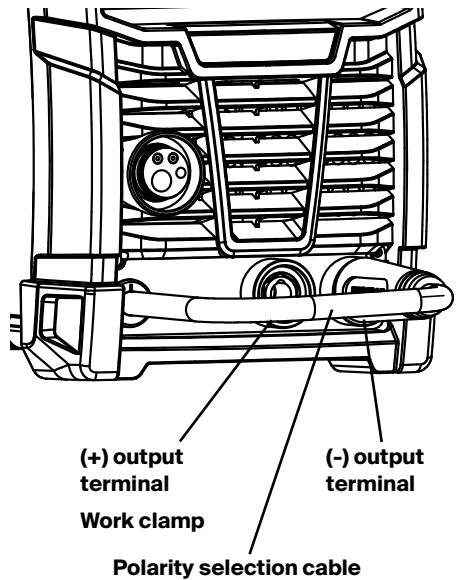

Fig 3 Negative Wire

Fitting the Gas Cylinder

Place the gas cylinder on the tray at the rear of the optional welder trolley (if using). Retain the cylinder with the chain provided.

Fit the gas regulator to the cylinder. DO NOT apply grease or oil to these joints.

Fit the end of the gas inlet hose from the back of the power source to the connector supplied with the gas regulator, and secure with the clamp also supplied.

Fitting the Gun and Cable Assembly

The supplied gun/cable assembly is equipped with a 'Euro' wirefeeder connector which incorporates all required connection points for welding current, shielding gas and gun switch control.

To attach the gun/cable assembly to the wirefeeder mechanism, engage the mating parts of the male and female Euro connectors, then rotate the locking ring clockwise to firmly secure the connection.

Fitting the Consumable Wire

Slide the spool over the retaining tab, locate the drive pin, and push spool up against the flange so the retaining tab engages the spool hub.

Check wire spool rotation tension.

Adjust spool holder wing nut to prevent over run of the wire spool at the end of a weld, without unduly loading the wirefeed motor.

Feeding the Consumable Wire

At the wirefeed assembly, release the compression screw by swivelling it outwards. This allows the top roller arm to spring to the open position. The end of the welding wire can now be passed through the inlet guide, over the bottom driven roller, and into the output wire guide tube. Check that the drive roll groove is correct for the wire in use. The appropriate size is stamped on the visible side of the installed roller. Check also that the correct size contact tip is fitted at the gun end. Feed roller and tip details are shown in Section 11 of this manual.

Return the top roller arm to the closed position and adjust the compression screw to provide sufficient clamping of the drive roll to achieve constant wirefeed. Do not over tighten.

With the equipment energised, operate the gun switch to feed wire through the gun cable. Holding the trigger for 5 seconds without welding will allow wire to feed at maximum speed.

Wire "Inch" - "Load"

When the trigger is pressed the wire will slowly feed out, until the wire touches the work piece, then the arc will start and wire speed will change to selected speed.

If the wire does not touch work piece within 5 seconds, then the wire speed will increase to maximum to assist wire loading. The wire speed cannot be adjusted during this time.

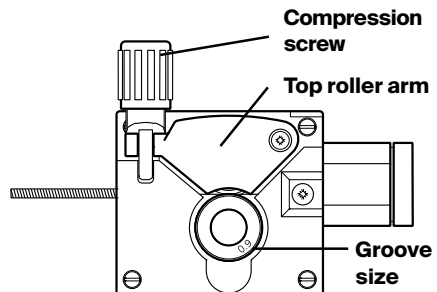

6 NORMAL WELDING SEQUENCE

Weld Start

The wire feed has an in built “creep” function.

When the trigger is pressed the wire will slowly feed out, until the wire touches the work piece, then the arc will start, wire speed will change to set speed.

Closing the welding gun switch initiates this sequence of events:

- The gas valve is energised and gas flow commences;
- Welding voltage is applied between the work piece and the consumable wire.
- The wire drive motor is energised.
- The wire creeps out.
- The wire touches the work piece, and the arc is established.
- Wire speeds up to selected speed

Weld End

Releasing the gun switch initiates this sequence of events:

- The wire drive motor is de-energised, and is dynamically braked to a stop;
- The welding current stops.
- The gas valve is de-energised and the flow of shielding gas ceases.

The quality of the consumable wire greatly affects how reliably a gas metal arc welder will operate. For best results when welding mild steel, we recommend quality WIA AUSTMIG ES6. Dirty, rusty or kinked wire will not feed smoothly through the gun cable and will cause erratic welding. Deposits from the wire will clog the gun cable liner requiring it to be replaced prematurely.

7 BASIC WELDING INFORMATION

Choice of Shielding Gas

The choice of shielding gas is largely determined by the consumable wire to be used. Many proprietary shielding gas mixtures are available.

The recommended shielding gases for use with the Weldmatic 200 are:

- Mild Steel : Argon + 18% Oxygen ;
Argon + 2% Oxygen + 5% Carbon dioxide;
- Aluminium: Argon;
- Stainless Steel: Argon + 1 to 2% Oxygen.

Consult your gas supplier if more specific information is required.

Shielding Gas Flow Rate

In GMAW, one function of the shielding gas is to protect the molten weld pool from the effects of oxygen in the atmosphere. Without this protection the weld deposit becomes ‘honeycombed’ in appearance, an effect which is described as weld porosity.

In draft-free conditions the gas flow rate required to give adequate protection is typically 10-12 litres/min. In situations where drafts cannot be avoided, it may be necessary to increase this rate up to 20 litres/min, and/or to provide screening of the work area.

Weld porosity can also be caused by air entering the gas stream through a damaged hose, loose gas connection, or from restriction in the nozzle, such as from excess build-up of spatter.

When welding aluminium, particular care must be taken with all aspects of shielding gas delivery and workpiece preparation in order to avoid weld porosity.

Establishing a Weld Setting

Once the consumable wire type, wire size and shielding gas have been chosen, the two variables that are adjusted in order to obtain the desired weld setting are;

- Wirefeed speed,
- Welding arc voltage.

The Weld Settings Chart in Figures 6a, 6b, and 6c can be used to preset the machine for an approximate welding current. For any voltage control settings, there is a range of valid wire speed settings.

Wirefeed speed is adjusted by Knob in Figure 1 (7). The wirefeed speed determines the welding current; increasing the speed increases the current, and decreasing it decreases current.

The selected wirefeed speed must be matched with sufficient arc voltage; a speed increase requires an increase of arc voltage.

If the voltage is too low the wire will stub and stutter, and there will not be a steady arc. If the voltage is too high the arc will be long with metal transfer occurring as a series of large droplets.

The weld setting should be chosen to suit the application and the thickness of the metal to be welded. It is important to check that the deposited weld provides sufficient strength to suit the application.

A “good” weld will have the characteristics illustrated in Figure 4. The weld has penetrated into the parent metal, fusing the root of the joint where the two plates meet, and the weld blends smoothly into the side walls.

A “bad” weld is shown in Figure 5. The weld has not penetrated the joint root, and there is poor side wall fusion. This lack of fusion would normally be corrected by increasing the arc voltage, or by increasing both wirefeed speed and arc voltage to achieve a higher current weld setting.

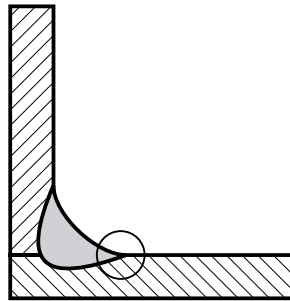

Fig 4 “Good” Weld

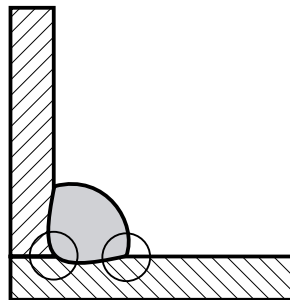

Fig 5 “Bad” Weld

WELDMATIC SETTINGS CHART

Suggested Settings for Fillet Weld Mild Steel – Gasless Wire

Wire Type

Gasless / Flux Cored
 Negative Polarity
 Knurled Drive Roll
 Arc Control 1

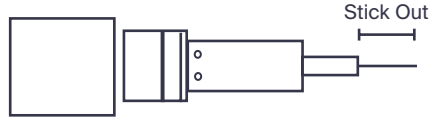

Material Thickness	Wire Size								
	0.8mm			0.9mm			1.2mm		
	Wirefeed	Volts	Stick Out	Wirefeed	Volts	Stick Out	Wirefeed	Volts	Stick Out
8mm 							5.0	19.0	15mm
5mm 	6.0	17.0	10mm	7.0	18.0	12mm	4.5	17.0	15mm
3mm 	5.5	16.0	10mm	5.6	17.0	12mm	2.5	15.5	15mm
1.6mm 	4.5	14.0	10mm	2.6	14.0	12mm	2.0	14.5	15mm
1.2mm 	2.8	13.0	10mm	2.4	13.0	12mm			
0.8mm 	2.0	13.0	10mm						

Fig 6a Weld Settings Chart

WELDMATIC SETTINGS CHART (CONT)

Suggested Settings for Fillet Weld Mild Steel – Solid Wire

Wire Type

Carbon Steel ES6
 Positive Polarity
 Gas: Ar + 5% CO₂ + 2% O₂
 Arc Control 5







Material Thickness	Wire Size					
	0.6mm		0.8mm		0.9mm	
	Wirefeed	Volts	Wirefeed	Volts	Wirefeed	Volts
8mm 					10.5	24.5
5mm 			11.5	22.5	9.5	22.5
3mm 	13.0	22.0	7.0	20.0	5.5	19.5
1.6mm 	7.5	18.5	4.0	17.5	3.5	16.5
1.2mm 	5.0	17.0	3.5	16.5	2.8	15.5
0.8mm 	4.0	16.0	3.0	16.0		

Fig 6b Weld Settings Chart

WELDMATIC SETTINGS CHART (CONT)

Suggested Settings for Fillet Weld Mild Steel – Solid Wire

Wire Type

Carbon Steel ES6
 Positive Polarity
 Gas: Ar + 18% CO₂
 Arc Control 5

Material Thickness	Wire Size					
	0.6mm		0.8mm		0.9mm	
	Wirefeed	Volts	Wirefeed	Volts	Wirefeed	Volts
8mm 					10.0	23.5
5mm 			10.5	24.0	9.0	22.0
3mm 	9.5	21.0	6.5	20.0	5.5	19.5
1.6mm 	7.0	18.5	4.5	17.5	3.7	17.0
1.2mm 	5.0	17.0	3.5	16.5	3.0	16.0
0.8mm 	4.0	16.5	2.8	16.0		

Fig 6c Weld Settings Chart

Gun Position

For “down hand” fillet welding with gas shielded solid wires, the gun is normally positioned as shown in Figure 7a below, with the nozzle end pointing in the direction of travel.

For “down hand” fillet welding with gasless flux cored wires, the gun is normally positioned as shown in Figure 7b, with the nozzle end pointing away from the direction of travel, referred to as ‘dragging’ the weld. Gasless flux cored wires should be operated with approximately 10-15mm of wire ‘stick-out’ from the welding contact tip as shown in Figure 7c.

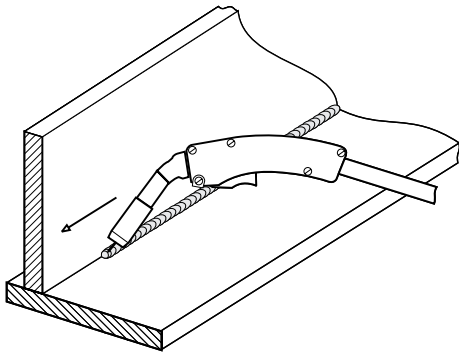

Fig 7a Gas Shielded Solid Wires

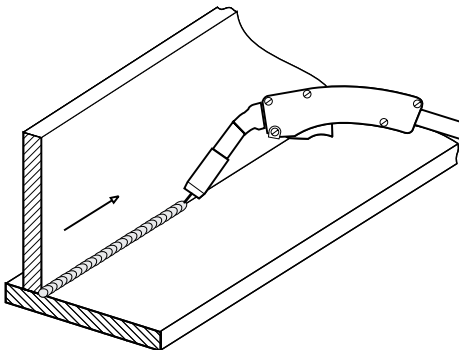

Fig 7b Gasless Flux Cored Wires

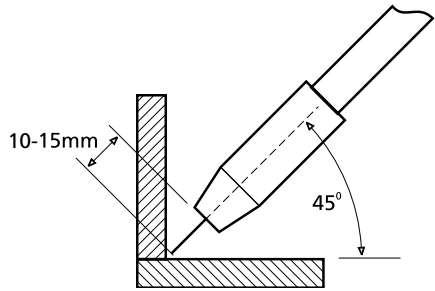
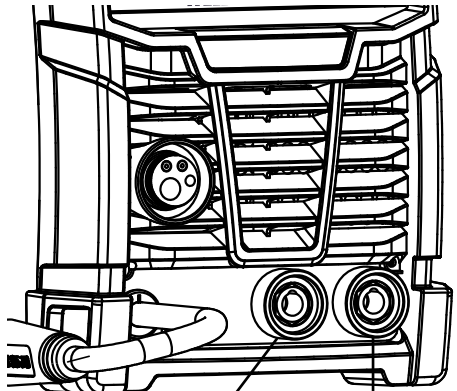

Fig 7c Wire Stickout for Gasless Welding

Stick Welding (MMAW)

Connection for Stick Welding

It is important to select the electrode polarity in accordance with the manufacturers recommendations for that electrode. Most common electrodes, including cellulose types, are operated with the electrode at positive polarity, as illustrated in Figure 8.



(+) Output Terminal To Electrode Holder (-) Output Terminal Work clamp

Fig 8 Connections for stick welding (MMAW), electrode positive

Stick Welding Operation

Be certain that you are wearing suitable protective clothing, gloves etc and that you are working in a non-hazardous area. If necessary, refer again to Section 1 - Safe Practices in this manual.

Connect the work clamp to the work piece. Place the desired electrode in the electrode holder.

Turn on the power switch located on the rear panel. Wait approximately 5 seconds as the unit goes through its initiation sequence.

Press the Weld Mode button until the Stick Mode light is on.

Select an appropriate welding current for the electrode diameter by setting the knob on the machine front panel. WIA AUSTARC electrodes will give the best results.

To strike the arc, drag the end of the electrode along the work piece as if striking a match. As the arc initiates, lift the electrode slightly away, aiming to establish an arc length of approximately 3 mm.

As the electrode end is consumed, feed the electrode into the arc in order to maintain arc length. As a general rule, the arc should be held as short as possible while still giving stable burn off and good weld appearance. An arc which is too long cause an unwieldy flow of metal with a rough weld appearance and reduced penetration. An arc too short leads to a narrow weld deposit and “stuttery” arc characteristics, and the electrode is liable to freeze onto the work piece.

As the solidified weld deposit forms, move the end of the electrode slowly along the weld path, aiming to maintain a pool of molten weld metal behind the arc. Decreasing this rate of travel will result in a wider weld deposit, and similarly increasing it will narrow the weld deposit.

Always fill the crater which tends to form at the end of a weld deposit, by pausing momentarily before withdrawing the electrode to break the arc. Unfilled craters are a point of weakness, and can lead to weld cracking.

Current Range for General Purpose Electrodes

Diameter (mm)	Current (Amps)
2.0	40 - 60
2.5	60 - 85
3.2	90 - 130
4.0	130 - 180

TIG Welding (GTAW)

Connection for TIG Welding

For TIG welding, the torch is connected to the negative terminal. Figure 9 illustrates the correct connection of the welding torch and gas supply. Welding grade Argon is the shielding gas most commonly used for DC GTAW welding. The gas is connected directly to the torch.

Before first use of the welding torch, allow gas to purge the torch and hoses for 5 minutes at approximately 10 litres/min. For welding purposes, the gas flow rate should be set in the range 2-5 litres/min.

Tungsten electrodes for DC GTAW should be 1-2% Thoriated or Witstar. This type will provide the best arc initiation, arc stability and tip shape retention characteristics. Thoriated electrodes can be recognised by a red coded end. The tungsten electrode is ground to a point, with the grinding marks pointing towards the tip. For welding currents less than 20 amps, the included angle of the point should be 30°, for currents greater than 20 amps, the recommended angle is 60°. When set in the torch, the tungsten should protrude 6 mm from the ceramic gas nozzle.

TIG Welding Operation

Connect the Work Clamp to the work piece.

Turn on the power switch located on the rear panel. Wait approximately 5 seconds as the unit goes through its initiation sequence.

Press the Weld Mode button until the TIG Mode light is on. The Weldmatic keeps the last mode used in memory, so this step is only necessary when using a different mode to that used last.

Select an appropriate welding current for the job by setting the knob on the machine front panel.

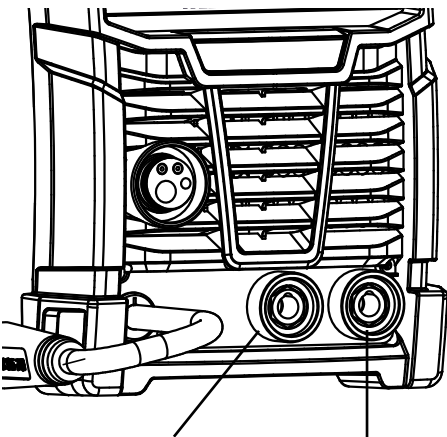

(+) Output Terminal Work clamp
 (-) Output Terminal To TIG Torch

Fig 9 Cable and hose connections for TIG welding

LIFT TIG Operation

When the Welding mode is set to LIFT TIG then the arc start can be achieved with the following procedure.

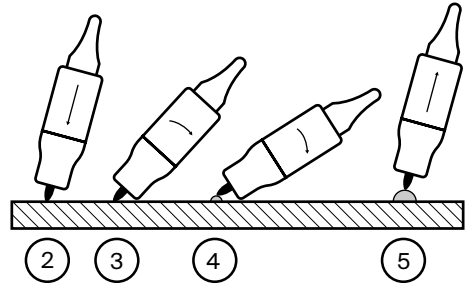

Fig 10 Lift TIG Operation Procedure

- 1 Turn on the torch gas valve. Gas will start to flow on torch.
- 2 Touch the electrode lightly against the work piece. A small current will pass through the electrode.
- 3 While still holding the electrode against the work piece, roll the hand piece over until the cup rests on the work piece.
- 4 Use the cup as a pivot point to roll the hand piece over allowing the electrode to lift of the work piece.

The arc will ignite.

- 5 Immediately lift the cup of the work piece, the current will rise to the welding level within the up-slope time.

Use of a copper striking plate can be used to avoid electrode contamination. The electrode can also be contaminated by contact with the filler rod. A contaminated electrode produces an unstable arc. If this occurs regrind the electrode tip.

Duty Cycle

The term duty cycle indicates the percentage welding time available at the rated output current, for each 10 min period over 4 hours.

The Weldmatic 200 is rated 200 Amps, 15% duty cycle. If the machine is operated at a reduced welding current, a higher duty cycle is available. The diagram below illustrates the appropriate duty cycle rating for the range of welding currents available from the 200 and so allows the maximum welding time per 10 minute period to be determined.

The power source is protected by in built over temperature protection devices. These will operate if the machine is operated in excess of its current and duty cycle rating. If this occurs, the fan will continue to run, but the machine will not deliver welding current until the unit has cooled sufficiently.

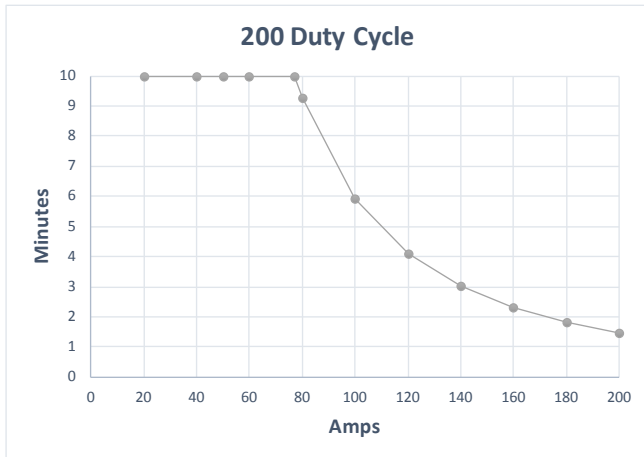

8 GENERAL MAINTENANCE

Before removing the equipment cover, ENSURE that the equipment is disconnected from the mains power supply. When the equipment is energised LETHAL VOLTAGES are present on the electrical components enclosed.

Dust

Care should be taken to prevent excessive build-up of dust and dirt within the welding power source. It is recommended that at regular intervals, according to the prevailing conditions, the equipment covers be removed and any accumulated dust be removed by the use of a dry, low pressure compressed air, or a vacuum cleaner. The machine should be blown out with compressed air at least every 12 months as grinding dust can settle on PCB componentry causing failure. Failure to maintain machines may void warranty.

Wirefeed

In order to obtain the most satisfactory welding results from the GMAW process, the wirefeed must be smooth and constant. Most causes of erratic wirefeed can be cured by basic maintenance. Check that the:

- 1 Feed rolls are the correct size and type for the wire in use. Check also that the drive groove is aligned with the wire, and that the groove is not worn;
- 2 Gun cable liner is clear of dust and swarf build-up. When replacement becomes necessary, fit only the correct liner (see page 35). The build-up of dust can be minimised by regular purging of the liner with dry compressed air. This may be conveniently done each time the wire spool is replaced;
- 3 Welding tip is free of obstructions such as spatter build-up. Ream out the tip bore with a suitable size oxy-tip cleaner. Replace the welding tip as it becomes worn;
- 4 Feed roll pressure is not excessive. The pressure should be just sufficient to feed the wire evenly. Excessive pressure will deform the electrode wire and make feeding more difficult;
- 5 Consumable wire spool holder rotates smoothly and that the braking action is not excessive. The spool should only have sufficient braking to prevent over run when the motor stops. This also may be conveniently checked each time the wire is replenished;
- 7 Welding wire is straight and free of buckles or 'waviness'. To check, remove 2 or 3 metres of wire from the spool. Clamp one end in a vice or similar, then holding the other end pull the wire out straight. Look down the length of the wire, any buckles will be obvious. Buckled wire is extremely difficult to feed reliably and should be replaced;
- 8 Welding wire is free of surface rust. Replace if rust is evident.

9 EXTERNAL TROUBLE SHOOTING

If you are in Australia and the following checks do not identify the fault condition, the equipment should be returned to a WIA Service agent. Phone 1300 300 884 for details of your nearest service agent.

If you are in New Zealand and the following checks do not identify the fault condition, the equipment should be returned to the original place of purchase with proof of purchase, or contact Weldwell on 06 8341 600.

10 TROUBLE SHOOTING CHART

Problem	Likely Reason	Outcome
All Inverter Multi-Process Models		
No welding current, no display.	The machine is not turned on at both the mains supply and the machine power switch.	If confirmed that the machine is switched on correctly, test the same outlet using a known serviceable appliance.
Mains Circuit breaker nuisance tripping during welding.	Mains Circuit breaker inadequately rated, or duty cycle exceeded.	The circuit breaker may be rated for leff (effective current). If Weld output is greater than the 100% rating the machine will require mains current higher than leff. The duty cycle should be observed and understood
Machine continually cuts out on thermal overload	The machine duty cycle has been exceeded.	Leave the machine energized, with the fan running until the machine has cooled sufficiently. The duty cycle should be observed and understood.
No welding current, display on.	The connections may not be made securely.	Ensure all connections are in position and securely made.
Machine gives poor quality weld.	The polarity of the electrode/return cables is incorrect.	Polarity should be confirmed for the process/wire type in use.
	The return lead contacts, or workbench surface requires cleaning.	The return lead contacts and connections should be inspected and cleaned, and the workbench cleared of waste materials.
Machine works fine on mains power but does not work when connected to a generator.	Generator cannot provide high peak cycle currents for inverter.	Use larger kVA generator or sometimes a different band generator will work.
Machine works fine on mains power but does not work when connected with extension lead.	Extension leads creating additional resistance, and voltage drop	Use larger cable size, and keep extension lead as short as possible.

Problem	Likely Reason	Outcome
MMA/STICK Models		
In MMAW (Stick), the arc is difficult to strike.	The technique required for VRD enabled welding machines is not the same as earlier stick welding units.	The technique to strike should be reviewed, not as a 'strike' but more as 'touch, twist, lift' motion. If VRD is not a site requirement, VRD can be disabled by service agent .
GMAW/MIG Models		
The machine feeds slowly and then speeds up after 3-5 seconds.	Creep mode is selected, or machine has a permanent creep mode function.	Some models have a creep mode function that cannot be adjusted. Other models have a push button selection for creep mode on/off.
Nothing happens for first x seconds after trigger is pulled.	Pre gas is selected to x seconds.	Pre gas selection should be wound off below 0 seconds.
The arc starts normally but then stops x seconds.	Spot time is selected to x seconds.	Spot time selection should be wound off below 0 seconds.
The arc does not stop after trigger is released.	Latch mode is selected.	Latch mode should be switched off.
Motor continues to run once arc is extinguished.	Latch mode is selected.	Latch mode should be switched off.
Weld is contaminated with small bubbles (presence of porosity).	Air in the gas hose. The torch gas hose has not been purged sufficiently.	Purge the system and confirm sufficient gas flow through the regulator.
	The gas hose is not securely connected at the machine or at the regulator.	Ensure the gas connections from regulator through to the torch connection are sufficiently tightened.
	Air is being drawn into arc through torch nozzle	Remove nozzle, check O ring on torch head, check condition of insulator in nozzle

Problem	Likely Reason	Outcome
GMAW/MIG Models (cont.)		
Wire feed stutters and arc is erratic. Also, motor turns correctly under no load.	Torch consumables are blocked/partially blocked.	Liners and contact tips are consumable and wear over time.
	Rusty MIG Wire.	Replace the torch liner and reduce wire feed tension.
Presence of porosity at weld start.	The torch gas hose has not been purged sufficiently.	Purge the system and confirm sufficient gas flow through the regulator.
GTAW/TIG Models		
Tungsten burns up on arc start.	The polarity of the electrode/return cables is incorrect.	Polarity should be confirmed for the process/wire type in use.
	Gas not turned on. Gas flow too low. Not enough Pregas time.	Review gas set up.
The weld has small black 'lumps' or 'dots' appearing in the pool. Cleaning is poor.	Old or dirty filler rods can often be the cause of 'dirty' TIG welding operations.	Switching filler rods to another type or batch may solve this issue.
Weld is contaminated with small bubbles (presence of porosity).	The gas hose is not securely connected at the machine or at the regulator.	Ensure the gas connections from regulator through to the torch connection are sufficiently tightened.
Presence of porosity at weld start.	The torch gas hose has not been purged sufficiently.	Purge the system and confirm sufficient gas flow through the regulator.

11 SERVICE INFORMATION

The following information is intended for use by qualified service personnel. As the unit is energised LETHAL VOLTAGES are present on the electrical and electronic components. It is not intended that persons without suitable training and knowledge attempt to perform service tasks on the components of this welder.

Before removing the equipment cover, ENSURE that the equipment is disconnected from the mains power supply. When the equipment is energised LETHAL VOLTAGES are present on the electrical components enclosed.

If the welding machine requires service or repair, take the machine to an authorised service agent. Australian service agents can be located on the welding.com.au website. Alternatively call customer service; Australian 1300 300 884 New Zealand 0800 9353 9355. When contacting a service agent please have an accurate description of the fault, and the machine serial number located on the base of the machine.

C1502A.....

11.1 CIRCUIT DIAGRAMS – POWER SOURCE

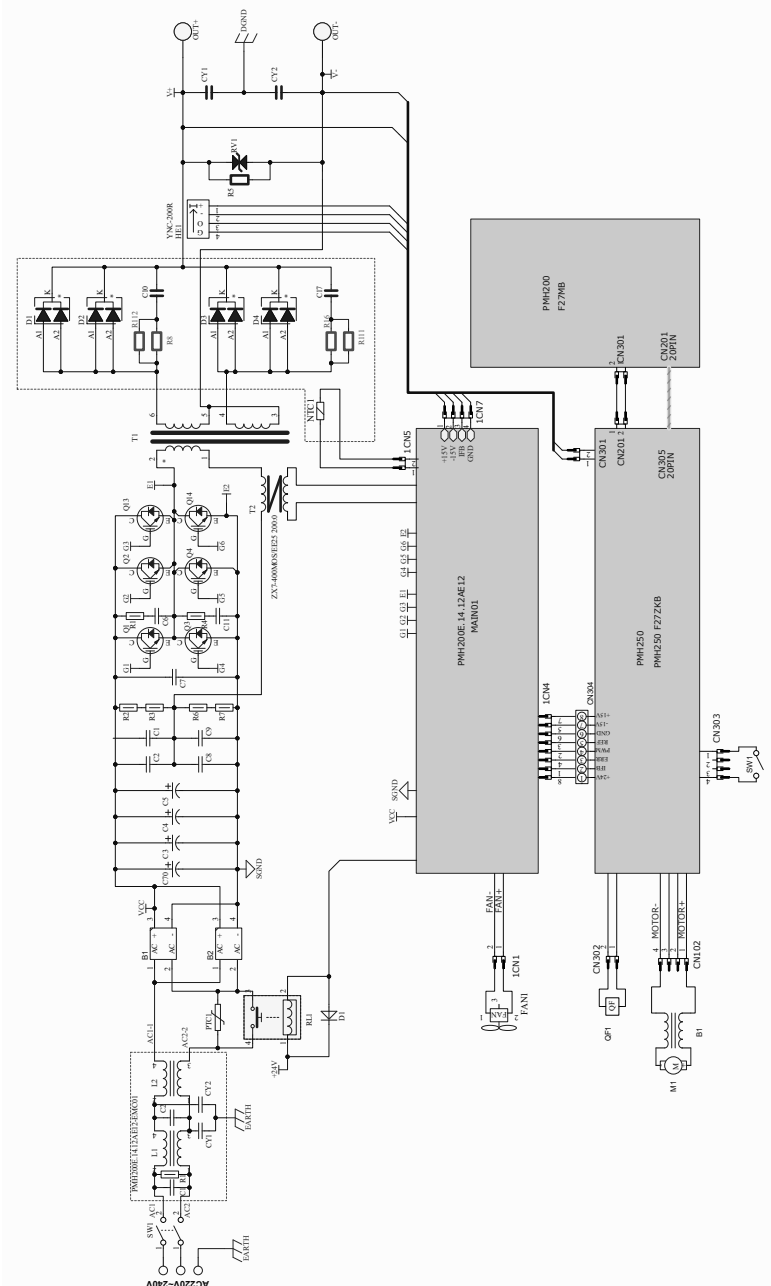

12.1 ASSEMBLY AND PARTS LIST - WELDMATIC 200 POWER SOURCE

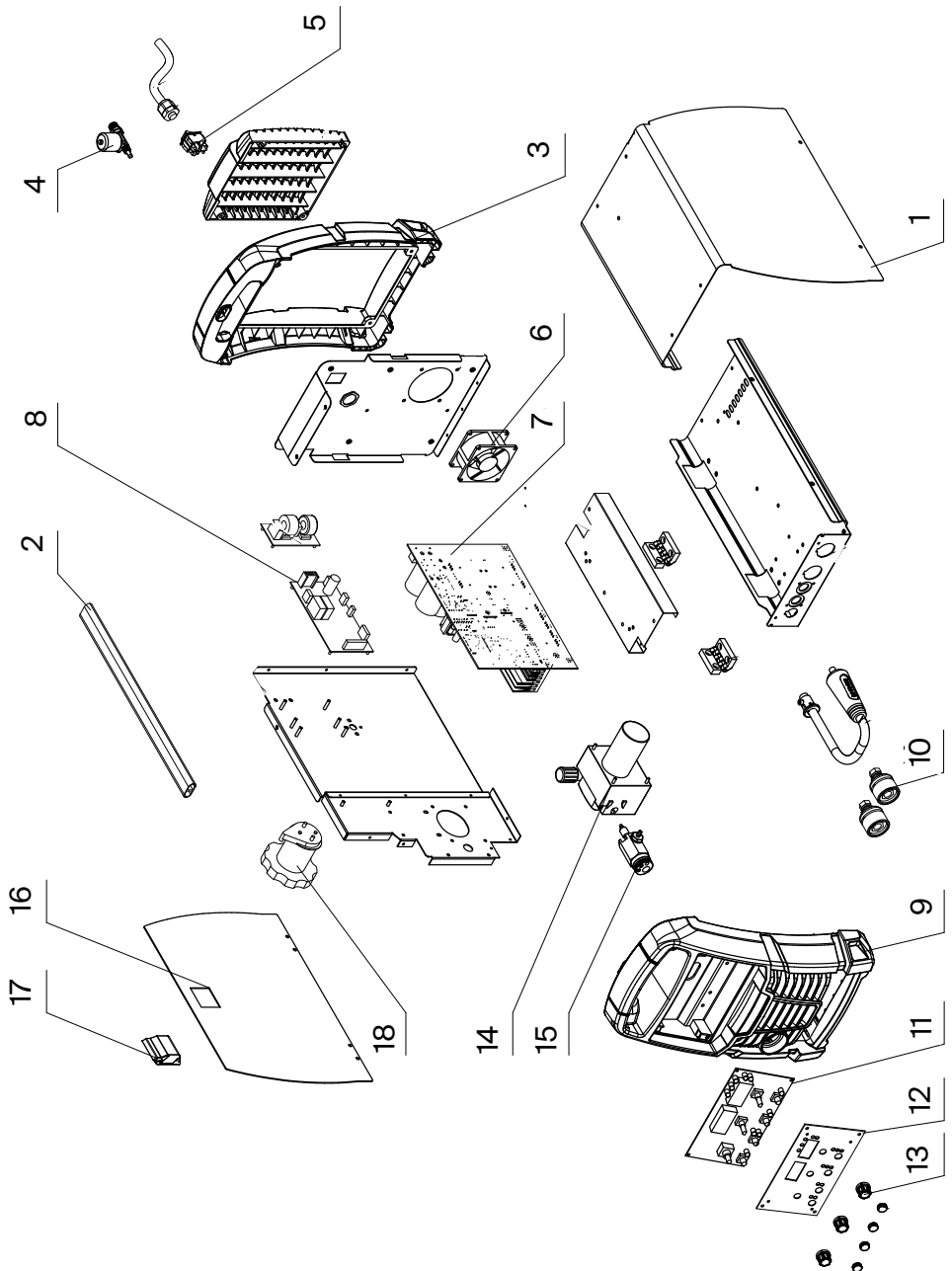

Item #	Part #	Description	Qty
1	PAN198	Outer Cover	1
2	M0109	Handle	1
3	M0137	Rear Panel	1
4	E0041	Gas Valve	1
5	E0078	Main Switch	1
6	FAN011	Fan	1
7	PWA112	Main Control Panel PCB	1
8	PWA113	Wirefeeder Control PCB	1
9	M0138	Front Panel	1
10	SA140-0/2	Dinse Socket	2
11	PWA114	Front Panel Control PCB	1
12	WIN540	Front Panel Sticker	1
13	M0104	Knob	3
14	WF055	Wire Drive Assembly	1
15	WF056	Euro Adaptor	1
16	PAN199	Side Door	1
17	M0049	Latch	1
18	M0082	Wire Spool Holder Assembly	1
19	REG003	Argon Regulator	1
20	CLA002	Work Clamp	1
21	62513	Blue Oxy Single Gas Hose, 5 mm	1
Not shown	CP137-40	Operating Manual	1

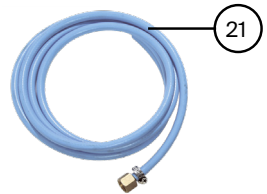
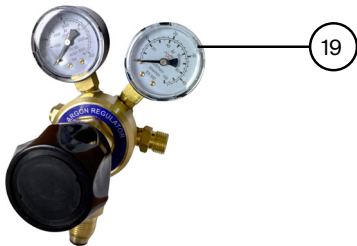

12.2 ASSEMBLY AND PARTS LIST - WIREFEEDER 200

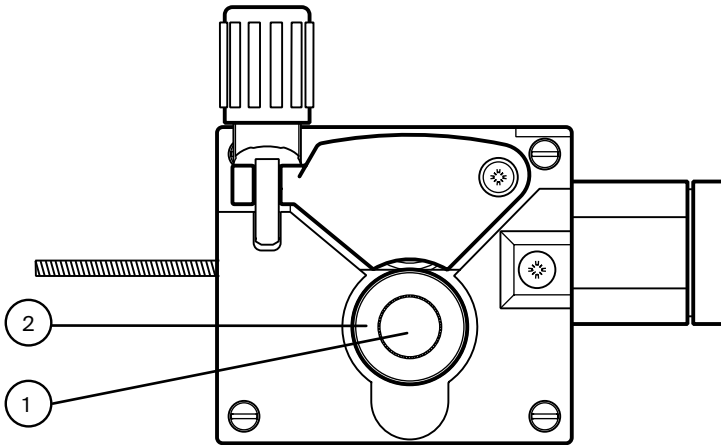

Fig 15 Wirefeed Assembly

Item #	Part #	Description	Qty
1	W27-0/9	Retaining Screw	1

Feed Rolls

Item #	Part #	Description
2	W26-0/8	0.6 + 0.8mm, Solid Wire
2	W26-8/8	0.8 + 0.9mm, Solid Wire
2	W26-7/8	1.0//1.2mm, Flux Cored Wire (knurled)
2	W26-9/8	0.9//1.2mm, Flux Cored Wire (knurled)
2	W26-3/8	1.0/1.2mm, Aluminium

12.3 ASSEMBLY AND PARTS LIST - GUN AND CABLE ASSEMBLY

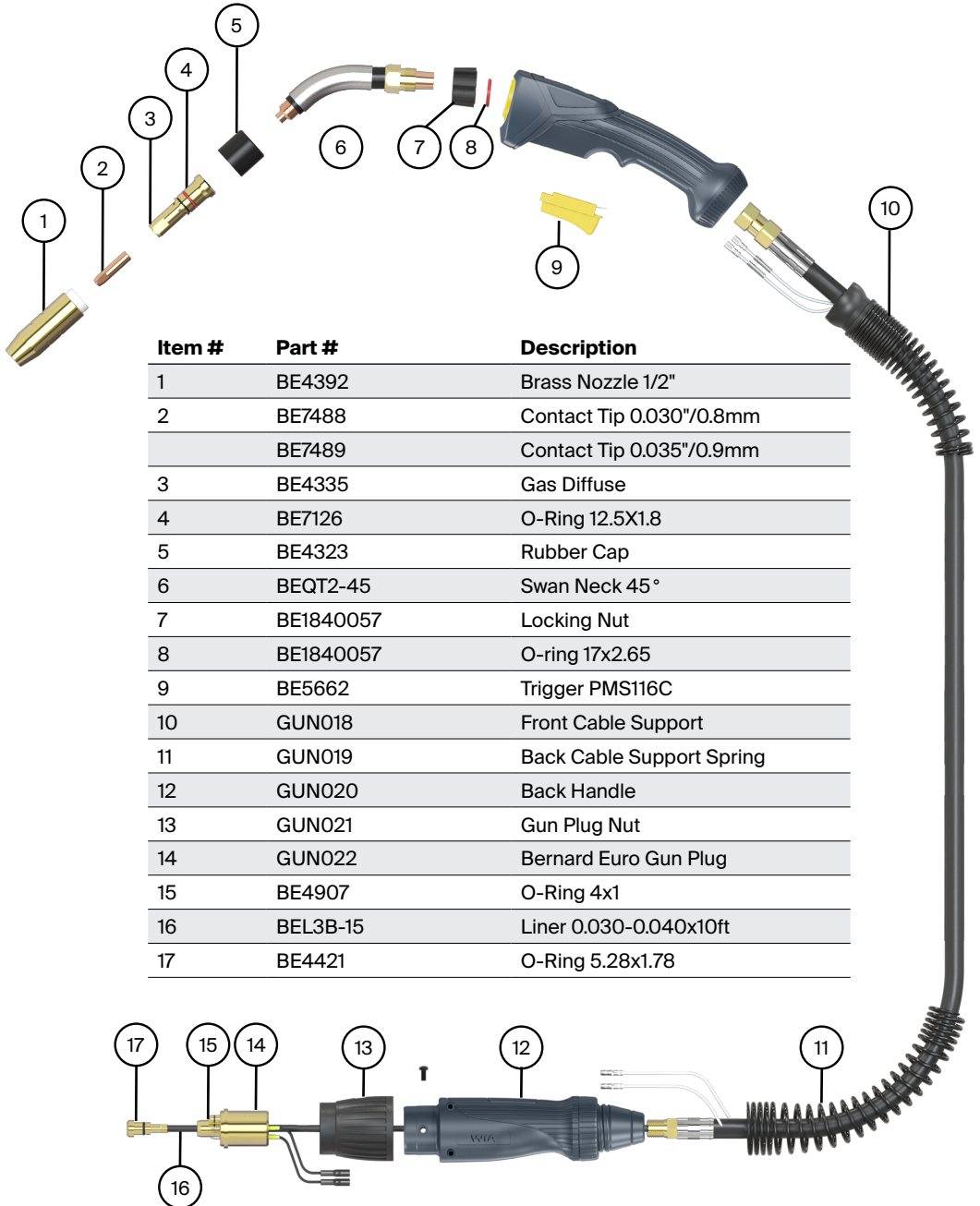

Item #	Part #	Description
1	BE4392	Brass Nozzle 1/2"
2	BE7488	Contact Tip 0.030"/0.8mm
	BE7489	Contact Tip 0.035"/0.9mm
3	BE4335	Gas Diffuse
4	BE7126	O-Ring 12.5X1.8
5	BE4323	Rubber Cap
6	BEQT2-45	Swan Neck 45°
7	BE1840057	Locking Nut
8	BE1840057	O-ring 17x2.65
9	BE5662	Trigger PMS116C
10	GUN018	Front Cable Support
11	GUN019	Back Cable Support Spring
12	GUN020	Back Handle
13	GUN021	Gun Plug Nut
14	GUN022	Bernard Euro Gun Plug
15	BE4907	O-Ring 4x1
16	BEL3B-15	Liner 0.030-0.040x10ft
17	BE4421	O-Ring 5.28x1.78

Fig 17 GUN011 (200 amp) Gun and Cable Assemble

Tips

Wire diameter	Short series (25mm)
0.6mm	BE7497
0.8mm	BE7488
0.9mm	BE7489
1.0mm	BE7496
1.2mm	BE7490

To replace liner: Disconnect gun/cable assembly at the Euro adaptor. Remove nozzle (1) and head (3). Withdraw old liner from the wirefeeder end. Insert new liner and refit gun/cable assembly to the wirefeeder.

At the gun end, compress the liner within the gun cable, then cut it 20mm past the end of the body tube (5). Refit head, tip and nozzle.

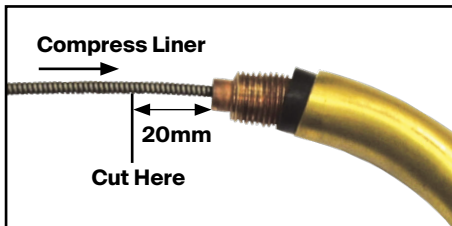

Fig 15 Replacing the gun cable liner

13 AUSTRALIAN WARRANTY INFORMATION



WIA Weldmatic MIG & Weldarc MMA Equipment

3 Year Gold Shield Warranty Statement

Effective 1st January 2022

Welding Industries of Australia (WIA) warrants to the original retail purchaser that the Weldmatic welding machine purchased (Product) will be free from defects in materials and workmanship for a period of 3 years from the date of purchase of the Product by the customer. If a defect in material or workmanship becomes evident during that period, Welding Industries of Australia will, at its option, either:

- Repair the Product (or pay for the costs of repair of the Product); or
- Replace the Product.

In the event of such a defect, the customer should return the Product to the original place of purchase, with proof of purchase, or contact Welding Industries of Australia on 1300 300 884 to locate an authorised service agent.

Products presented for repair may be replaced by refurbished products of the same type rather than being repaired. Refurbished parts may be used to repair the product. Replacement of the product or any part does not extend or restart the Warranty Term. The repair of your products may result in the loss of any user-generated data. Please ensure that you have made a copy of any data saved on your product.

Any handling and transportation costs (and other expenses) incurred in claiming under this warranty are not covered by this warranty and will not be borne by Welding Industries of Australia.

Welding Industries of Australia will return the replacement product, if original found to be faulty, freight free to the customer.

This warranty covers the Weldmatic power source and wirefeeder only, and does not extend to the regulator, gun assembly or accessories included in the original purchase package.

The obligation of Welding Industries of Australia under this warranty is limited to the circumstances set out above and is subject to:

- The customer being able to provide proof of purchase of the Product and the purchase price paid for the Product;
- The relevant defect in materials or workmanship;
- The Product not having been altered, tampered with or otherwise dealt with by any person in a manner other than as intended in respect of the relevant Product; and
- The Product not having been used or applied in a manner that is contrary to customary usage or application for the relevant Product or contrary to any stated instructions or specification of Welding Industries of Australia.

Our goods come with guarantees that cannot be excluded under the Australian Consumer Law. You are entitled to a replacement or refund for a major failure and for compensation for any other reasonably foreseeable loss or damage. You are also entitled to have the goods repaired or replaced if the goods fail to be of acceptable quality and the failure does not amount to a major failure.

The benefits given by this warranty are in addition to other rights and remedies which may be available to the customer under any law in relation to goods and services to which this warranty relates.

Warranty provided by:

Welding Industries of Australia

(ABN 63 004 235 063)

A Division of ITW Australia Pty Ltd

5 Allan Street, Melrose Park
South Australia 5039

1300 300 884

Email: info@welding.com.au

Web: www.welding.com.au

14 NEW ZEALAND WARRANTY INFORMATION



WIA Weldmatic MIG & Weldarc MMA Equipment

3 Year Gold Shield Warranty Statement

Effective 1st January 2022

WIA Weldmatic MIG & Weldarc Equipment purchased in New Zealand have identical warranty conditions as Australia, with the below conditions:

In the event of defects listed in the Australian warranty conditions, the customer should return the Product to the original place of purchase, with proof of purchase, or contact Weldwell on 0800 9353 9355.

The warranty shall not apply to parts that fail due to normal wear.

For customers located in New Zealand, you can contact:

Weldwell New Zealand

Division of ITW New Zealand

64 Thames Street

Napier 4110

New Zealand

0800 9353 9355

Email: info@weldwell.co.nz

Web: www.weldwell.co.nz

NOTES:

NOTES:

NOTES:



WELDING INDUSTRIES AUSTRALIA

A Division of ITW Australia Pty Ltd

ABN: 63 004 235 063

1300 300 884

Email: info@welding.com.au

welding.com.au

WELDWELL NEW ZEALAND

A Division of ITW New Zealand

NZBN: 9 429 039 833 129

GST NO: 080 177 186

0800 9353 9355

Email: info@weldwell.co.nz

weldwell.co.nz

CP150-40 RevD

WELD WITH THE BEST.

WELDING.COM.AU